

# QUAD CITY Aircraft Corp.

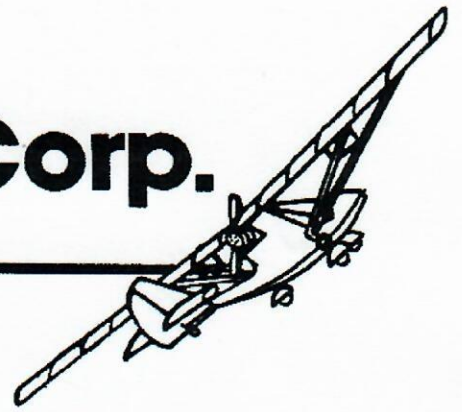

Your guide for ordering assemblies and parts for your Challenger I, II, LSS, or XL aircraft.

# 2020 Parts Price List

Quad City Aircraft

232 38<sup>th</sup> St

Moline, IL 61265

309 764 3515

[www.qcaircraft.com](http://www.qcaircraft.com)

[rusty@qcaircraft.com](mailto:rusty@qcaircraft.com)

[sarah@qcaircraft.com](mailto:sarah@qcaircraft.com)

All prices and part numbers in this list are subject to change without notice. Please contact the factory for updated pricing before ordering.

**CONTENTS:****PAGE #**

Tail Section-assemblies & parts.....	1
Challenger I Wings and special wings.....	2
Challenger II Wings and special wings.....	3
Challenger LSS & XL Wings and speical wings.....	3
Wing Gussets, Rib kits.....	4
Ailerons.....	5
Lift struts .....	5
Jury struts, Streamline Strut Fairings.....	6
Leading Edge Wrap kits.....	6
Wing Tip Box kits.....	6
Flaperons.....	6
Wing Accessories, .....	6
Challenger I Fuselage.....	7
Challenger I Controls.....	8
Challenger II Fuselage.....	8
Challenger II Fuselage Cont.....	9
Challenger II Controls.....	9
Challenger LSS & XL Fuselage.....	10
Fuselage gussets and horns.....	10
Stringer Assemblies.....	11
Dorsal fins.....	12
Pushrods, Stab Struts.....	12
Fuel Tanks.....	12
Throttle and fuel system.....	13
Landing gear-Main and Nose.....	13
Landing gear-Main and Nose cont.....	14
Wheels & tires.....	14
Fiberglass parts.....	15
Brake kits.....	16
Door kits.....	16
Cushions, Seat Belts, & Shoulder Harnesses.....	17
Fabric-Sailcloth Wings.....	17

Fabric-Stits, Wings, Fuselage, Tails.....	18
Motor mount kits.....	18
Exhaust and parts.....	19
Reduction drive and parts.....	19
Starters.....	19
Instruments.....	20
Aircraft Hardware.....	20
Aircraft Hardware Cont.,Decals.....	22
Misc Hardware Kits.....	22
Special UL hardware, Rivets.....	22
Rivets cont., Misc. hardware.....	23
Bolt Guide for Aircraft Hardware.....	25
Nose Gear Breakdown.....	26
Wing and Fuselage drawings.....	27-32

part number	description	Price	unit	Qty per A/C
<b>EMPENAGE SECTION ( TAIL, Section 1)</b>				
EMP-100	RUDDER ASSY.	\$126.06	Each	1
EMP-200	VERTICAL FIN ASSY.	\$144.02	Each	1
EMP-300	HORIZONTAL STABILIZER ASSY.	\$182.20	Each	2
EMP-400	ELEVATOR ASSY.	\$124.38	Each	2
EMP-100-UK	RUDDER ASSY-UK	\$131.64	Each	1
EMP-200-UK	VERTICAL FIN ASSY-UK	\$197.02	Each	1
EMP-100-XL	RUDDER ASSY-XL	\$139.52	Each	1
EMP-200-XL	VERTICAL FIN ASSY-XL	\$171.45	Each	1
EMP-100-LSS	RUDDER ASSY-LSS	\$116.56	Each	1
EMP-200-LSS-1	VERTICAL FIN ASSY-LSS-SQ TAIL	\$189.74	Each	1
EMP-200-LSS-2	VERTICAL FIN ASSY-LSS-RD TAIL	\$189.74	Each	1
EMP-001	rudder LE (leading edge) tube	\$15.28	Each	1
EMP-002	rudder TE (trailing edge) tube	\$23.66	Each	1
EMP-003	rudder x-brace tube	\$9.77	Each	1
EMP-004	rudder horn brace tube	\$5.96	Each	1
EMP-005	vertical fin LE tube	\$25.46	Each	1
EMP-006	vertical fin TE tube	\$16.92	Each	1
EMP-007	vertical fin x-brace tube	\$9.88	Each	1
EMP-008	stabilizer LE tube	\$37.96	Each	2
EMP-009	stabilizer TE tube	\$18.89	Each	2
EMP-010	stabilizer inner sleeve tube	\$14.74	Each	4
EMP-011	stabilizer x-brace tube	\$10.57	Each	4
EMP-012	elevator LE tube	\$18.89	Each	2
EMP-013	elevator TE tube	\$37.96	Each	2
EMP-014	elevator x-brace tube	\$10.66	Each	4
EMP-1	gusset for all square corners	\$2.25	Each	26
EMP-2	gusset for 90 deg. x-tubes	\$2.25	Each	18
EMP-2SP	gusset for vert. fin x-brace	\$2.25	Each	4
EMP-3	gusset for rudder horn brace	\$2.25	Each	4
EMP-5	gusset inboard corner of elev.	\$2.25	Each	4
EMP-6	gusset (elev. & rud.) x-tube	\$2.25	Each	6
LSS-DFVFG	Dorsal Fin to Vertical Fin Gusset	\$6.90	Each	1
EMP-7-L	horn, left elevator	\$7.31	Each	1
EMP-7-R	horn, right elevator	\$7.31	Each	1
EMP-8-L	horn, left rudder	\$7.31	Each	1
EMP-8-R	Horn, right rudder	\$7.31	Each	1
LSS-EMP-8-L	horn, left rudder XL	\$8.26	Each	1
LSS-EMP-8-R	horn, right rudder XL	\$8.26	Each	1
LSS-RH-001	rudder horn hdwr. bag	\$3.17	Each	1
LSS-RS-100	rudder stop assy. set	\$9.82	Set	1
LSS-RS	rudder stop, white pvc ( 3" x 1/2" x 3/4" )	\$2.89	Each	1
LSS-PVC-1	rudder stop spacer, gray pvc ( 1" x 1/2" )	\$1.49	Each	1
TT-100	Trim tab set w/hdwr (set of three)	\$29.35	Each	1
TT-003	Trim tab w/hdwr (one set)	\$10.76	Each	3
TT-001	Trim tab only	\$4.19	Each	3

part number	description	Price	unit	Qty per A/C
TT-002	Trim tab hdwr only (set of three)	\$19.71	Each	1
TT-004	Trim tab hdwr only (one set)	\$6.57	Each	3
SFM-100	Stab fin mod kit (1P & 2P) with saddles	\$76.15	Each	1
SFM-001	stab fin mod hdwr only	\$30.42	Each	1
SFM-002	stab fin mod plywood sheet only	\$16.43	Each	2
SFM-003	stab fin mod alum. saddle only		Each	4
<b>SINGLE PLACE ULTRALIGHT WING SECTION: (SECTION II)(not available as Clip Wing)</b>				
W-100-R	WING PANEL ASSY. UL right	\$831.25	Each	1
W-100-L	WING PANEL ASSY. UL left	\$831.25	Each	1
W-001	spar assy., 1P UL front left & right	\$232.97	Each	2
W-002-R	spar assy., 1P UL right rear	\$239.66	Each	1
W-002-L	spar assy., 1P UL left rear	\$239.66	Each	1
W-003	compression strut, 1P main	\$21.64	Each	2
W-004	compression strut, 1P secondary	\$17.42	Each	4
W-005	drag/anti-drag strut, 1P	\$21.96	Each	4
W-006	wing tip bow assy., 1P	\$46.61	Each	2
W-006A	wing tip bow LE tube, 1P	\$27.59	Each	2
W-006B	wing tip bow TE tube, 1P	\$10.45	Each	2
W1	triangle wing gusset (all wings)	\$2.25	Each	
W2	rect. wing gusset ( all wings)	\$2.25	Each	
WT-1	wing tip gusset ( all wings)	\$2.25	Each	
<b>SINGLE PLACE STANDARD WING SECTION:</b>				
W-200-R	WING PANEL ASSY, 1P STD RIGHT	\$896.73	Each	1
W-200-L	WING PANEL ASSY, 1P STD LEFT	\$896.73	Each	1
W-201	spar assy, 1 P STD front	\$360.11	Each	2
W-202-R	spar assy,1 P STD right rear	\$405.14	Each	1
W-202-L	spar assy, 1 P STD left rear	\$405.14	Each	1
W-003	compression strut, 1P main	\$21.64	Each	2
W-004	compression strut, 1P secondary	\$17.42	Each	4
W-005	drag/anti-drag strut, 1P	\$21.96	Each	4
W-006	wing tip bow assy., 1P	\$46.61	Each	2
W-006A	wing tip bow LE tube, 1P	\$27.59	Each	2
W-006B	wing tip bow TE tube, 1P	\$10.45	Each	2
W1	triangle wing gusset (all wings)	\$2.25	Each	
W2	rect. wing gusset ( all wings)	\$2.25	Each	
WT-1	wing tip gusset ( all wings)	\$2.25	Each	
<b>SINGLE PLACE CLIP WING SECTION:</b>				
W-100X-L	WING PANEL ASSY., 1P CW LEFT	\$755.57	Each	1
W-100X-R	WING PANEL ASSY., 1P CW RIGHT	\$755.57	Each	1
W-001X	spar assy., 1P CW front	\$210.95	Each	2
W-002X-L	spar assy., 1P CW left rear	\$214.31	Each	1
W-002X-R	spar assy., 1P CW right rear	\$214.31	Each	1
W-003	compression strut, 1P main	\$21.64	Each	2

part number	description	Price	unit	Qty per A/C
W-004	compression strut, 1P secondary	\$17.42	Each	3
W-005	drag/anti-drag strut, 1P	\$21.96	Each	3
W-006	wing tip bow assy., 1P	\$46.61	Each	2
W-006A	wing tip bow LE tube, 1P	\$27.59	Each	2
W-006B	wing tip bow TE tube, 1P	\$10.45	Each	2
W1	triangle wing gusset (all wings)	\$2.25	Each	
W2	rect. wing gusset ( all wings)	\$2.25	Each	
WT-1	wing tip gusset ( all wings)	\$2.25	Each	
<b>TWO PLACE STANDARD WING SECTION:</b>				
2W-100-R	WING PANEL ASSY., 2P STD. RIGHT	\$1,007.26	Each	1
2W-100-L	WING PANEL ASSY., 2P STD. LEFT	\$1,007.26	Each	1
2W-001	spar assy., 2P STD. front	\$299.82	Each	2
2W-002-R	spar assy., 2P STD. right rear	\$343.70	Each	1
2W-002-L	spar assy., 2P STD. left rear	\$343.07	Each	1
2W-003	compression strut, 2P main	\$29.46	Each	2
2W-004	compression strut, 2P secondary	\$21.64	Each	4
2W-005	drag/anti-drag strut, 2P	\$31.30	Each	4
2W-006	wing tip bow assy., 2P	\$66.12	Each	2
2W-006A	wing tip bow LE tube 2P	\$31.00	Each	2
2W-006B	wing tip bow TE tube 2P	\$10.46	Each	2
2W-006C	wing tip bow brace tube	\$8.69	Each	2
W1	triangle wing gusset (all wings)	\$2.25	Each	
W2	rect. wing gusset ( all wings)	\$2.25	Each	
WT-1	wing tip gusset ( all wings)	\$2.25	Each	
<b>TWO PLACE CLIP WING SECTION:</b>				
2W-100X-R	WING PANEL ASSY., 2P CW RIGHT	\$962.30	Each	1
2W-100X-L	WING PANEL ASSY., 2P CW LEFT	\$962.30	Each	1
2W-001X	spar assy., 2P CW front	\$269.30	Each	2
2W-002X-L	spar assy., 2P CW left rear	\$308.76	Each	1
2W-002X-R	spar assy., 2P CW right rear	\$308.76	Each	1
2W-003	compression strut, 2P main	\$29.46	Each	2
2W-004	compression strut, 2P secondary	\$21.64	Each	6
2W-005	drag/anti-drag strut, 2P	\$31.30	Each	6
2W-006	wing tip bow assy., 2P	\$66.12	Each	2
2W-006A	wing tip bow LE tube 2P	\$31.00	Each	2
2W-006B	wing tip bow TE tube 2P	\$10.46	Each	2
2W-006C	wing tip bow brace tube	\$8.69	Each	2
W1	triangle wing gusset (all wings)	\$2.25	Each	
W2	rect. wing gusset ( all wings)	\$2.25	Each	
WT-1	wing tip gusset ( all wings)	\$2.25	Each	
<b>TWO PLACE LIGHT SPORT SPECIAL WING SECTION:</b>				2
LSS-2W-100-L	WING PANEL 2P. LSS LEFT	\$962.96	Each	
LSS-2W-100-R	WING PANEL 2P. LSS RIGHT	\$962.96	Each	

part number	description	Price	unit	Qty per A/C
LSS-2W-100L-LW	WING PANEL 2P. LSS LEFT, LONG WING	\$1,007.26	Each	1
LSS-2W-100R-LW	WING PANEL 2P. LSS RIGHT, LONG WING	\$1,007.26	Each	1
XL-2W-100-L	WING PANEL 2P. XL-65 LEFT, WITH WING TANK BAY	\$1,204.46	Each	1
XL-2W-100-R	WING PANEL 2P. XL-65 RIGHT, WITH WING TANK BAY	\$1,204.46	Each	1
LSS-2W-003	leading edge spar extension, 6" x 1 7/8" x .049	\$14.56	Each	1
LSS-2W-004	trailing edge spar extension, 12" x 1 3/4" x .058	\$20.23	Each	
LSS-2W-005	leading edge spar extension splice 8" w/ rivets (ss short)	\$21.55	Each	2
LSS-2RB1X	wing rib, 2P. top (fabric)	\$22.04	Each	2
LSS-2RB2X	wing rib, 2P. bottom (fabric)	\$15.80	Each	2
LSS-2RB1X-A	wing rib, 2P. Special top ( longer, for wing tip angle)	\$22.87	Each	28 - 32
LSS-2RB2X-A	wing rib, 2P.Special bottom ( longer, for wing tip angle)	\$20.10	Each	14 - 16
LSS-BRC2	bottom rib channel ( 8 per set)	\$10.61	Each	2
LSS-W5X-CH	channel flat sheet, bottom( 6 x 59" w/1" 90 deg. bends)	\$44.96	Each	2
LSS-W5X	wing flat sheet, top inboard ( 8" x 62" )	\$46.36	Each	8
LSS-WTT-2W5X	wing tip flat sheet top, ( 61.5 x 10.5 x 5.5 ) .020	\$34.66	Each	2
LSS-WTB-2W5X	wing tip flat sheet bottom, ( 59" x 10.5" x 5.5" ) .020	\$34.66	Each	2
LSS-RWTWS	rear wing tip wrap sheet (.016 soft alum. sheet)	\$22.12	Each	
LSS-RWTFR	rear wing tip filler rib	\$9.71	Each	2
LSS-WTB	wing tip brace L-bracket material ( 20" x 2" x 3/4" ) .025	\$11.72	Each	2
LSS-WTBS	wing tip brace sheet (24" x 4 1/2" ) .025	\$27.62	Each	4
LSS-W1XX	wing rib gusset	\$2.25	Each	3
W1X	wing rib gusset, bottom	\$2.25	Each	2
LSS-LEW-STIF	leading edge stiffner u-channel	\$6.86	Each	26 - 32
XL-WT-RB-WEB-L	wing tank rib bay webs, front & rear, left side	\$69.24	Set	26 - 32
XL-WT-RB-WEB-R	wing tank rib bay webs, front & rear, right side	\$69.24	Set	8
LSS-WTC-L	wing tank cover, Left	\$52.62	Each	1
LSS-WTC-R	wing tank cover, right	\$52.62	Each	1
LSS-A-100L-LW	aileron assy., left, LONG WING ONLY 9"	\$326.40	Each	1
LSS-A-100R-LW	aileron assy., right, LONG WING ONLY 9"	\$326.40	Each	1
XL-A-100-L	aileron assy., left, Long Wing, 7"	\$449.76	Each	1
XL-A-100-R	aileron assy., right, Long Wing, 7"	\$449.76	Each	1
<b>SAILCLOTH RIBS</b>				
RB-1	wing rib stay, 1P (for use with sails)	\$10.85	Each	22
2RB-1	wing rib stay, 2P (for use with sails)	\$15.77	Each	22
<b>FABRIC RIB KITS (to covert from Sailcloth to Stits Fabric)</b>				
RB-100	1P STD. rib kit complete w/tapes & hdwr (fabric wing)	\$1,211.51	Each	1
RB-100X	1P CW rib kit complete w/tapes & hdwr (fabric wing)	\$1,104.85	Each	1
RB-200	2P STD. rib kit complete w/tapes & hdwr (fabric wing)	\$1,285.97	Each	1
RB-200X	2P CW rib kit complete w/tapes & hdwr (fabric wing)	\$1,175.33	Each	1
<b>The following items (2)RB1X thru W6X comprise the fabric rib kits</b>				
RB-1X	wing rib, 1P top	\$19.82	Each	STD-32
RB2X	wing rib, 1P bottom	\$17.63	Each	4

part number	description	Price	unit	Qty per A/C
2RB1X	wing rib, 2P top (fabric)	\$22.00	Each	STD-32
2RB2X	wing rib, 2P bottom (fabric)	\$18.25	Each	4
W1X	wing rib gusset (all fabric ribs)	\$2.25	Each	STD-56
W5X	wing flat sheet, 1P top & bottom	\$24.18	Each	4
2W5X	wing flat sheet, 2P top & bottom	\$31.57	Each	4
W8X	wing flat sheet, top inboard 2P LSS, 8" x 62"	\$44.14	Each	2
W6X	spar to tip fairing gusset	\$3.15	Each	4
W7LX	lexan center section cover	\$17.52	Each	1
DFR-1	rib, wing end, dorsal fin	\$5.03	Each	2
DFR-2	rib, wing end dorsal fin	\$6.10	Each	2
<b>AILERON SECTION:</b>				
A-100-L	AILERON ASSY., LEFT STD	\$329.76	Each	1
A-100-R	AILERON ASSY., RIGHT STD	\$329.76	Each	1
A-001	aileron LE tube, STD	\$99.62	Each	2
A-002	aileron TE tube, STD	\$43.63	Each	2
A-001-LES	aileron L.E. splice 8"	\$14.15	Each	2
A-001-LEX	aileron LE extension w/smash	\$51.76	Each	2
A-100X-L	AILERON ASSY., LEFT CW	\$300.77	Each	1
A-100X-R	AILERON ASSY., RIGHT CW	\$300.77	Each	1
A-001X	aileron LE tube, CW	\$62.81	Each	2
A-002X	aileron TE tube, CW	\$31.61	Each	2
A-003	aileron rib, main (all wings)	\$5.76	Each	16
A-004	aileron rib, inboard (all wings)	\$5.03	Each	2
A-005	aileron rib, outboard (all wings)	\$4.70	Each	2
A-006	aileron control horn (all wings)	\$5.28	Each	2
A-007	aileron hinge (all wings)	\$12.18	Each	8
A-007-A	aileron hinge pin ONLY, s.s.	\$1.24	Each	8
<b>LIFT STRUTS- SINGLE PLACE &amp; U/L</b>				
S-001	lift strut, 1P STD front	\$109.57	Each	2
S-002-L	lift strut, 1P STD left rear	\$117.34	Each	1
S-002-R	lift strut, 1P STD right rear	\$117.34	Each	1
<b>LIFT STRUTS- SINGLE PLACE CLIPPED WING:</b>				
S-001X	lift strut, 1P CW front	\$101.83	Each	2
S-002X-L	lift strut, 1P CW left rear	\$110.67	Each	1
S-002X-R	lift strut, 1P CW right rear	\$110.67	Each	1
<b>LIFT STRUTS- TWO PLACE STANDARD</b>				
2S-001	lift strut, 2P STD. front	\$106.26	Each	2
2S-002-L	lift strut, 2P STD. left rear	\$115.10	Each	1
2S-002-R	lift strut, 2P STD. right rear	\$115.10	Each	1
<b>LIFT STRUTS- TWO PLACE CLIPPED WING:</b>				
2S-001X	lift strut, 2P CW front	\$97.10	Each	2



part number	description	Price	unit	Qty per A/C
2S-002X-L	lift strut, 2P CW left rear	\$107.35	Each	1
2S-002X-R	lift strut, 2P CW right rear	\$107.35	Each	1
<b>JURY STRUTS</b>				
JS-200X	jury sturt set (all models after 8/94)	\$217.22	Each	1
JS-001X	jury strut hardware only	\$101.47	Each	1
JS-001	jury strut tubing only	\$96.46	Each	1
<b>STREAMLINED STRUT FAIRINGS:</b>				
SSF-100	fairing set - lift struts & gear legs (ABS plastic)	\$307.23	Set	1
SSF-001	10 ft. piece (ABS plastic)	\$83.85	Each	4
SSF-002	2 ft. piece (ABS plastic)	\$15.02	Each	2
JSF-100	jury strut fairing set, 4-- 5ft. pcs.	\$199.65	Set	1
JSHF-200	jury & horizational strut fairing set, 6-- 5ft.pcs.	\$241.34	Set	1
JSF-001	jury & horizontal strut fairing 5ft pc.	\$40.39	Each	4-6
<b>LEADING EGE WRAP KITS:</b>				
LEW-100X	leading edge wrap kit, CW	\$201.25	Set	1
LEW-200X	leading edge wrap kit, STD	\$293.49	Set	1
LEW-001	leading edge wrap 16" x 12' .020		Each	2
LEW-002	leading edge wrap 16" x 4' .020			
LEW-300	leading edge wrap kit, XL	\$504.54	Set	1
LEW-301	leading edge wrap 37" for long wing only		Each	2
LEW-302	leading edge wrap 73"		Each	2
LEW-303	leading edge wrap 61"		Each	2
<b>WING TIP BOX KITS: (required for fiberglass wing tips)</b>				
BT-100	boxed wing tip kit, 1P (sails)	\$197.46	Each	1
BT-100-X	boxed wing tip kit, 1P (fabric)	\$217.58	Each	1
BT-200	boxed wing tip kit, 2P (sails)	\$283.98	Each	1
BT-200-X	boxed wing tip kit, 2P (fabric)	\$308.14	Each	1
<b>FLAPERONS:</b>				
FLP-100	flaperon set	\$242.80	Each	1
FLP-200	flaperon set	\$247.65	Each	1
FLP-001	flaperon slide bracket only	\$94.50	Each	1
FLP-002	flaperon crank assy.	\$98.10	Each	1
FLP-003	flaperon crank brass fitting	\$21.15	Each	1
FLP-004	flaperon triangle bracket	\$7.70	Each	1
FLP-005-1	flaperon pushrod assembly 1pl			
FLP-005-2	flaperon pushrod assmbly 2pl			
FLP-006	flaperon crank handle w/threaded rod & nut			
FLP-007	flaperon slide assembly			
<b>SINGLE PLACE FUSELAGE (section 3) ( * for clipped wing add X )</b>				

part number	description	Price	unit	Qty per A/C
F-100 *	FUSELAGE ASSEMBLY COMPLETE	\$4,831.01	Each	1
F-101 *	Fuselage w/o controls	\$3,185.11	Each	1
F-102 *	Fuselage w/o controls & stringers	\$2,826.92	Each	1
F-103 *	Fuselage longeron base built	\$1,537.43	Each	1
F-001	rear longeron (undrilled)	\$149.42	Each	2
F-002	front longeron (undrilled)	\$43.16	Each	2
F-003	4" outer sleeve doubler	\$7.08	Each	2
MG-1	main gear weldments	\$112.50	Each	2
MG-100	main gear weldment replacement kit (one weldment per kit)	\$152.23	Each	
TP-1	tail post weldment	\$48.90	Each	2
CT-1	cross tube 1 ( 1/2" steel)	\$19.93	Each	1
CT-2	cross tube 2 (nose gear support)	\$34.38	Each	1
CT-3	cross tube 3 (front stick support)	\$34.36	Each	1
CT-4	cross tube (load carry thru)	\$36.54	Each	1
CT-5	cross tube (gear carry thru)	\$48.83	Each	1
CT-6	cross tube (rear cross tube)	\$19.19	Each	1
DT-1	down tube 1 (front)	\$60.82	Each	2
DT-2	down tube 2	\$45.52	Each	2
DT-3	down tube 3	\$45.51	Each	2
DT-4	down tube 4 assy. (rear)	\$51.22	Each	2
DT-5	sleeve 3"	\$5.04		
FB-1	brace tube	\$11.38	Each	2
FB-2	brace tube	\$34.14	Each	2
FB-3	brace tube	\$7.28	Each	2
FB-4	brace tube	\$14.57	Each	2
FB-5	brace tube	\$18.22	Each	2
FB-6	brace tube	\$6.10	Each	2
FB-7	brace tube	\$12.18	Each	2
FB-8	brace tube (w/inner sleeve) -- discontinued 12/97--	\$17.07	Each	1
FB-9	brace tube (w/inner sleeve)	\$18.49	Each	1
FB-10	brace tube	\$11.29	Each	1
FB-11	brace tube assy.	\$71.69	Each	1
FB-12	brace tube ( .5"x10.5")	\$5.00	Each	2
FB-12A	brace tube	\$5.00	Each	2
FB-16	pedal stop tube	\$9.00	Each	1
FB-16-NC	nose cone pedal stop tube	\$7.74	Each	1
FB-17	nose spreader tube	\$7.10	Each	1
FB-18T	rear engine former top (specify left or right)	\$9.46	Each	2
FB-18B	rear engine former bottom (specify left or right)	\$9.46	Each	2
FB-19	brace tube -- New 12/97 --	\$20.48	Each	1
FB-20	brace tube -- New 12/97 --	\$20.48	Each	1
FB-22	nose cone pedal stop brace tube	\$19.75	Each	2
PS-1	pedal spacer center piece	\$5.22	Each	1
PS-3	pedal spacer outboard pieces		Each	2
FWF-1	fuse., windshield former tube	\$21.62	Each	1
RT-1	root tube (drilled & stamped w/serial #)	\$246.83	Each	1

part number	description	Price	unit	Qty per A/C
<b>SINGLE PLACE CONTROLS:</b>				
C-001	control stick	\$28.48	Each	1
C-002	main elev. pushrod tube	\$77.45	Each	1
C-002-NI	3" nylon insert	\$5.24	Each	1
C-003-L	pedal assy., 1P left	\$47.08	Each	1
C-003-R	pedal assy., 1P right	\$47.08	Each	1
C-004	cable assy., 1P aileron	\$90.64	Each	2
C-005	cable assy., 1P rudder	\$129.58	Each	2
C-006	cable assy., idler	\$8.76	Each	1
C-007	pulley assy., 1P aileron	\$38.62	Each	4
C-008	pulley assy., idler	\$6.08	Each	1
<b>TWO PLACE FUSELAGE section 3 ( * for clipped wing add X)</b>				
2F-100 *	FUSELAGE ASSY. COMPLETE, 2P STD	\$6,335.65	Each	1
2F-101 *	Fuselage w/o controls	\$4,183.49	Each	1
2F-102 *	Fuselage w/o controls & stringers	\$3,735.32	Each	1
2F-103 *	Fuselage base, seats & belts	\$2,218.14	Each	1
2F-001	longeron, 2P rear (undrilled)	\$162.62	Each	2
2F-002	longeron, 2P front (drilled w/all sleeves)	\$200.35	Each	2
2F-002A	longeron, 2P front (undrilled w/o sleeves)	\$62.56	Each	2
2F-003	sleeve, 2P inner ( 2 ft.)	\$22.70	Each	2
2F-004	sleeve, 2P outer doubler 6"	\$11.64	Each	2
MG-1	main gear weldments	\$112.50	Each	2
MG-100	main gear weldment replacement kit (one weldment per kit)	\$152.23	Each	
TP-1	tail post weldment	\$48.90	Each	2
2CT-1	cross tube 1 ( 1/2" steel tube)	\$20.48	Each	1
2CT-2	cross tube (nose gear support)	\$37.09	Each	1
2CT-3	cross tube (front stick support)	\$41.64	Each	1
2CT-4	cross tube 4 (load carry thru)	\$41.53	Each	1
2CT-5	cross tube 5 ( rear stick support)	\$42.64	Each	1
2CT-6	cross tube 6 ( rear seat support)	\$36.50	Each	1
2CT-7	cross tube 7 ( gear carry thru)	\$57.02	Each	1
2CT-7A	diagonal cross tubes	\$11.38	Each	2
2CT-8	cross tube 8 (ties in CT-7A's)	\$11.38	Each	1
2CT-9	cross tube 9 (rear cross tube)	\$11.38	Each	1
2DT-1	down tube 1 (front)	\$44.75	Each	2
2DT-1A	down tube (front seat back support) (after 12/97)	\$39.68	Each	2
2DT-1A-OS	down tube (front seat back support for sling seats)	\$33.07	Each	2
2DT-2	down tube 2	\$37.46	Each	2
2DT-3	down tube 3	\$37.46	Each	2
2DT-4	down tube 4	\$40.55	Each	2
2FB-1	brace tube	\$10.07	Each	2
2FB-2	brace tube	\$41.65	Each	2
2FB-3	brace tube	\$7.21	Each	2
2FB-4	brace tube	\$8.33	Each	2

part number	description	Price	unit	Qty per A/C
2FB-5	brace tube	\$6.98	Each	2
2FB-6	brace tube	\$4.75	Each	2
2FB-7	brace tube	\$10.44	Each	2
2FB-8	brace tube (w/inner sleeve) --discontinued 12/97 --	\$19.82	Each	1
2FB-9	brace tube (w/inner sleeve)	\$21.02	Each	1
2FB-10	brace tube	\$7.52	Each	1
2FB-11	brace tube	\$54.82	Each	1
2FB-12	brace tube (.5"x10.5")	\$6.32	Each	2
2FB-12A	brace tube	\$6.32	Each	2
2FB-14	brace tube (rear sling support) -- discontinued 12/97 --	\$7.29	Each	1
2FB-15	brace tube (front sling support) --discontinued 12/97 --	\$6.46	Each	1
2FB-16	pedal stop tube	\$9.95	Each	1
2FB-16-NC	pedal stop tube for nose cone	\$9.95	Each	1
2FB-17	nose spreader tube	\$7.10	Each	1
2FB-18	rear engine former (specify top or bottom & left or right)	\$10.74	Each	4
2FB-19	brace tube -- New 12/97 --	\$21.72	Each	1
2FB-20	brace tube -- New 12/97 --	\$21.72	Each	1
2FB-21	brace tube, tank support -- New 12/97 --	\$22.75	Each	1
2FB-22	nose cone pedal stop brace tube (-V- shape)	\$19.75	Each	2
2PS-1	pedal spacer, 2P inner	\$6.55	Each	1
2PS-3	pedal spacer, 2P outboard	\$3.44	Each	2
FWF-1	fuselage windshield former tube	\$21.61	Each	1
2RT-1	root tube, 2P, drilled & stamped w/serial #	\$293.32	Each	1
2FB-100X	Special Cockpit Mod Kit w/hdwr (included w/CW)	\$162.71	Each	1
2FB-2A	cockpit siderail, special mod ( high sides)	\$42.64	Each	2
CB-1SP	cockpit bow tube, special mod	\$17.17	Each	2
CR-1SP	cockpit rib #1, special mod	\$10.97	Each	2
CR-2SP	cockpit rib #2, special mod	\$9.42	Each	2
CR-3SP	cockpit rib #3, special mod	\$7.31	Each	2
<b>TWO PLACE CONTROLS:</b>				
2C-001	control stick, 2P front	\$28.67	Each	1
2C-002	control stick, 2P rear	\$30.89	Each	1
2C-003	control stick interconnect, 2P	\$23.80	Each	1
2C-004	main elevator pushrod, 2P	\$71.99	Each	1
2C-005	pedal assy., 2P left rear	\$47.08	Each	1
2C-006	pedal assy., 2P right rear	\$47.08	Each	1
2C-007	pedal assy., 2P left front	\$51.49	Each	1
2C-008	pedal assy., 2P right front	\$51.49	Each	1
2C-009	cable assy., 2P rear aileron	\$141.30	Each	2
2C-010	cable assy., 2P front aileron	\$152.10	Each	2
2C-011	cable assy., 2P rudder	\$131.40	Each	2
2C-013	pulley assy., aileron (1 pulley)	\$46.34	Each	4
2C-014	pulley assy., aileron (2 pulley)	\$94.04	Each	2
C-006	cable assy., idler	\$8.76	Each	1
C-008	pulley assy., idler	\$6.08	Each	1

part number	description	Price	unit	Qty per A/C
<b>LSS TWO PLACE FUSELAGE section 3</b>				
LSS-2F-100	FUSELAGE ASSY. COMPLETE, 2P LSS	\$5,471.24	Each	
LSS-2F-101	Fuselage w/o controls	\$3,632.22	Each	
LSS-2F-102	Fuselage w/o controls & stringers	\$3,258.40	Each	1
LSS-2F-103	Fuselage base, seats & belts	\$1,993.98	Each	1
LSS-2F-001	longeron, 2P. LSS rear (undrilled)	\$124.52	Each	1
LSS-2F-002	longeron, 2P. LSS front (drilled w/all sleeves)	\$166.96	Each	1
LSS-2F-002A	longeron, 2P. LSS front ( undrilled w/o sleeves)	\$52.13	Each	2
LSS-2F-003	sleeve, 2P. LSS inner	\$18.92	Each	2
LSS-2F-004	sleeve, 2P. LSS outer doubler	\$6.46	Each	2
LSS-TP	tail post, 2P. LSS	\$60.45	Each	2
LSS-MG-2	main gear weldment assy. LSS/ XS/ XL ONLY	\$291.06	Assy	2
LSS-TF	top former assy., LSS ONLY	\$19.20		quantity
LSS- TFFT	top former tube ( 15" x .50 x .035 )	\$5.30		per a/c
LSS-TFFA	top former angle ( 1" x 1" x .063 x 10.5 long)	\$10.14		
<b>LSS / XS50 / XL 65 CONTROLS:</b>				
LSS-2C-011	cable assy, LSS rudder (3/32)	\$88.34	Each	
LSS-STOP	cable stop, LSS choke	\$5.78	Each	
<b>CHALLENGER FUSELAGE GUSSETS:</b>				
FG-W1A	1P for CT-2,3 & 2P for CT-2,3,5	\$3.98	Each	8 - 12
FG-1	1P, ties in DT-2, FB-2,4,5	\$5.03	Each	4
FG-2	1P, ties in DT-3 & 4, FB-4,6 & 7	\$5.03	Each	4
FG-3	1P & 2P (DT-3 & 4 to longeron)	\$5.70	Each	4
FG-4L	1P & 2P (DT-1 to longeron)	\$5.70	Each	2
FG-4R	1P & 2P (DT-1 to longeron)	\$5.70	Each	2
FG-5	1P & 2P (FB-1 & 2 to longeron)	\$3.34	Each	2
FG-6	1P & 2P (ties FWF to DT-1)	\$5.03	Each	2
FG-7	1P & 2P (ties FB-1 to DT-1)	\$2.25	Each	4
FG-8	1P & 2P (ties FB-3 to FB-1 & 2)	\$2.25	Each	1
FG-9	1P & 2P (ties FB-10 to FB-11)	\$2.34	Each	1
FG-10	1P & 2P (ties FB-17 to FS-002)	\$2.25	Each	2
FG-10NC	gusset for spreader tube when using Nose Cone	\$2.25	Each	2
FG-11	nose plate, 1P	\$7.68	Each	1
FG-12	1P (T-junction behind tank)	\$6.35	Each	2
FG-99	1P & 2P (rear boom brace)	\$10.40	Each	2
2FG-1	2P (DT-2, 2FB-2,4,5)	\$6.35	Each	4
2FG-2	2P (2DT-3 & 4 to 2FB-4,6,7)	\$6.35	Each	4
2FG-11	nose plate, 2P	\$8.35	Each	1
2FG-12	2P (T-junction behind tank)	\$11.05	Each	2
AM-1	idler pulley mount plate, 1P	\$8.36	Each	1
2AM-1	idler pulley mount plate, 2P	\$8.69	Each	1
CP-1	choke plate, 1P --- discontinued 12/97 ---	\$17.70	Each	1
2CP-1	choke plate, 2P ---discontinued 12/97 ---	\$17.70	Each	1
UB-1A	u-bracket, aluminum --- discontinued 8/94 ---	\$2.24	Each	10

part number	description	Price	unit	Qty per A/C
UB-1S	u-bracket, stainless (for CT-1 & stab strut)--all planes--	\$3.96	Each	10
UB-2S	u-bracket, stainless(dor.fin&FB-12undrilled) --all planes--	\$1.82	Each	8
FCR-2	cockpit rib, 1P	\$10.04	Each	2
2FCR-1	cockpit rib, 2P front	\$8.36	Each	2
2FCR-2	cockpit rib, 2P middle	\$10.04	Each	2
2FCR-3	cockpit rib, 2P rear	\$10.56	Each	2
FFF-1	fuselage former, 1P front --New 12/97--	\$30.08	Each	1
RFF-1	fuselage former, 1P rear --New 12/97--	\$30.08	Each	1
FFF-2	fuselage former, 2P front --New 12/97--	\$32.10	Each	1
RFF-2	fuselage former, 2P rear --New 12/97--	\$32.10	Each	1
FD-1	fuel door assy., 1P & 2P a/c plywood	\$26.75	Each	1
FD-001	fuel door hinge only	\$9.72	Each	1
<b>MISCELLANEOUS GUSSETS &amp; HORNS:</b>				
PH-1	pedal horn, all models	\$4.03	Each	2
PH-2	pedal interconnect horn, 2P	\$4.03	Each	4
PH-3	pedal horn, 2P rudder	\$7.73	Each	2
TP-001	top former plate, 1P	\$9.97	Each	2
TP-002	top former plate, 2P	\$12.37	Each	2
SBP-1	seat back plate, bottom front	\$15.59	Each	1
SBP-2	seat back plate, rear of front seat	\$14.21	Each	1
SBP-3	seat back plate, top front	\$11.44	Each	1
<b>STRINGER ASSEMBLIES AND PARTS:</b>				
FS-100	STRINGER ASSY.,1P	\$89.33	Each	2
2FS-100	STRINGER ASSY., 2P	\$92.68	Each	2
2FS-101	Stringer Assy., complete, front 6 Ft. w/ splices	\$83.16	Each	2
FS-001	stringer, bottom 1P	\$43.16	Each	2
2FS-001	stringer, bottom 2P	\$44.88	Each	2
FS-002	top stringer	\$18.25	Each	2
FS-003	stringer brace	\$9.37	Each	2
FS-003NC	nose cone spreader tube, 1P	\$9.37	Each	1
2FS-003NC	nose cone spreader tube, 2P	\$10.85	Each	1
FS-004	stringer upright	\$12.76	Each	2
FS-005	stringer splice	\$5.65	Each	
FS-006	stringer, front 6' bottom stringer w/splices	\$20.94	Each	
2FS-007	stringer spreader tube, 2P	\$10.85	Each	1
FSR6	stringer rib, 1P 6"	\$12.76	Each	4 - 2 w/N.C.
2FSR6	stringer rib, 2P 6"	\$12.76	Each	6 - 4 w/N.C.
FSR5	stringer rib, 1P 5 3/4"	\$12.52	Each	2
2FSR5	stringer rib, 2P 5 3/4"	\$12.52	Each	2
FSR4	stringer rib, 4"	\$10.97	Each	2
FSR2	stringer rib, 2"	\$9.19	Each	2
NG-1	gusset	\$2.00	Each	4
	<b>all stringer parts are same for 1P &amp; 2P except where noted</b>			

part number	description	Price	unit	Qty per A/C
<b>MISCELLANEOUS FUSELAGE PARTS:</b>				
IG-1	ignition wiring 1P	\$4.75	Each	1
IG-2	ignition wiring 2P	\$5.30	Each	2
IN-1	instrument panel	\$16.76	Each	1
GRIP	foam grips- black	\$4.61	Each	1 - 2
<b>DORSAL FIN PARTS-CH I, CH II, XL</b>				
DF-100	DORSAL FIN ASSY.	\$68.63	Each	1
DF-1	dorsal fin gusset, front	\$2.25	Each	2
DF-2	dorsal fin gusset, bottom rear corner	\$2.25	Each	2
DF-3	dorsal fin gusset, top rear corner	\$2.25	Each	2
DF-4	dorsal fin upper tube			
DF-5	dorsal fin lower tube			
DF-6	dorsal fin rear tube			
DFR-1	dorsal fin rib-front	\$5.03	Each	1
DFR-2	dorsal fin rib-middle	\$6.10	Each	1
DFR-3	dorsal fin rib-rear	\$6.84	Each	1
<b>DORSAL FIN PARTS -UK</b>				
DF-100-UK	DORSAL FIN ASSY			
DF-1-UK	dorsal fin gusset, front	\$2.25		
DF-2-UK	dorsal fin gusset bottom rear corner	\$2.25		
DF-3-UK	dorsal fin gusset top rear corner	\$2.25		
DF-4-UK	dorsal fin upper tube			
DF-5-UK	dorsal fin lower tube			
DF-6-UK	dorsal fin rear tube			
DFR-1-UK	dorsal fin rib-front			
DFR-2-UK	dorsal fin rib-middle			
DFR-3-UK	dorsal fin rib-rear			
<b>PUSHRODS AND STAB STRUTS:</b>				
STB-100	stabilizer strut set w/hdwr	\$79.95	Each	1
STB-001	stab strut only	\$7.43	Each	4
STB-002	stab strut hdwr. only	\$2.65	Each	8
EL-100	elevator pushrod set w/hdwr	\$120.74	Each	1
AL-100	aileron pushrod set w/hdwr	\$80.16	Each	1
PL-100	pedal interconnect set, 2P w/hdwr (rudder)	\$70.93	Each	
EPMK-100	elevator pushrod mod kit	\$54.42	Each	
<b>FUEL TANKS:</b>				
TM-1-5	tank mount tube set (1P, 5 gal.)	\$22.06	Each	1
TM-2-5	tank mount tube set (2P, 5 gal.)	\$24.71	Each	1
TM-1-10	tank mount tube set (1P, 10 gal.)	\$22.91	Each	1
TM-2-10	tank mount tube (2P, 10 gal.)	\$13.88	Each	1
TT-5	tank tray set ( 5 gallon tank)	\$30.88	Each	1
TT-0-5	tank tray bottom (5 gallon tank)	\$11.34	Each	1

part number	description	Price	unit	Qty per A/C
TT-1-10	tank tray set (1P, 10 gal.)	\$33.10	Each	1
TT-2-10	tank tray set (2P, 10 gal.)	\$37.97	Each	1
TANK-10	10 gal. tank w/ pick up	\$146.65	Each	1
TANK-5	5 gal. tank w/pick up	\$64.63	Each	1
PRIMER	primer bulb	\$32.31	Each	1
FILTER	fuel filter	\$8.98	Each	1
FUEL-L	fuel line for all a/c	\$2.70	FT.	6'
FUEL-C	fuel tank cap	\$12.95	Each	1
FUEL-PU	fuel tank pick up tube only	\$24.44	Each	1
FUEL-015	bungee, tank hold down	\$11.00	Each	1
TANK-17 GAL	17 gallon fuel tank complete	\$1,017.60	Each	1
<b>THROTTLE AND FUEL SYSTEM PARTS CONT.:</b>				
TH-001	throttle cable, less quadrant, 1P (2 required for DC)	\$41.43	Each	1-2
TH-002	throttle cable, less quadrant, 2P (2 required for DC)	\$80.50	Each	1-2
TH-100	throttle cable & quadrant, 1P (SC)	\$56.42	Each	1
TH-102	throttle cable & quadrant, 1P (DC)	\$98.54	Set	1
TH-200	throttle cable & quadrant, 2P (SC)	\$55.91	Set	1
TH-202	throttle cables & quadrant, 2P (DC)	\$96.15	Set	1
TH-Q	throttle quadrant only	\$17.98	Each	1
TL-1	throttle lever	\$6.99	Each	1
TB-1	throttle bracket	\$5.46	Each	1
TH-203	throttle assy., 2P front (interconnect)	\$34.29	Each	1
TH-2	throttle bracket spacer, 1/2" gray pvc	\$1.25	Each	1
TH-3	throttle handle, 1" gray pvc w/hdwr	\$2.34	Each	1
TH-4	throttle rod, interconnect	\$1.16	FT.	
QCU-336-503C	throttle cable assy., 503 DC with 3 way spliter	\$127.66	Each	1
QCU-336-582C	throttle cable assy., 582 DC with 3 way spliter	\$127.66	Each	1
AC-396D-592C	throttle cable assy., 582 DC with 3 way spliter	\$127.66	Each	1
CC-100	choke cable, SINGLE CARB	\$44.84	Set	1
CC-102	choke cables, DUAL CARB	\$103.28	Set	1
<b>LANDING GEAR PARTS AND ASSEMBLIES:</b>				
LG-1	Gear leg-main, aluminum	\$73.66	Each	2
LG-1F	Gear leg-main, fiberglass	\$81.90	Each	2
LG-1XL	Gear leg-main, spun aluminum (for XL weldments only)	\$94.00	Each	2
LG-1A	gear leg insert - 6" x 1 1/4" chromoly steel	\$22.75	Each	2
LG-1B	gear leg outer sleeve, chromoly steel	\$25.17	Each	2
LG-2	axle weldment	\$105.00	Each	2
LG-2A	axle, 5/8"	\$19.24	Each	2
LG-2B	axle spacer, 1 5/8"	\$6.66	Each	2
LG-2C	5/8" thin nyloc (new lg-2 axle)	\$1.61	Each	2
LG-2AP	axle plug, machined for 5/8" axle	\$19.24	Each	2
LG-11	axle weldment XL		Each	1
LG-3	main landing gear cable 2P.	\$17.02	Each	2
LG-4	main landing gear cable 1P.	\$16.06	Each	2



part number	description	Price	unit	Qty per A/C
LG-5	Landing gear drag cable	\$40.40	Each	2
NG-100	nose gear assy. (w/hdwr, less fork)	\$190.80	Each	1
NG-001	nose gear carrier/ bearing sold seperate	\$103.50	Each	1
NG-002	nose gear shaft assy.	\$69.75	Each	1
NG-003	steering pushrod w/ball joint	\$26.30	Each	2
NG-004	nose gear fork spacer, bushing	\$2.64	Each	2
NG-005	nose gear shaft nut			
NG-006	nose gear shaft bearing set	\$15.08	Each	1
NG-007	nose gear pushrod only	\$7.30	Each	2
LG-100	nose gear fork assy. w/hdwr 5"	\$72.15	Each	1
LG-6	nose gear fork, 5"	\$52.11	Each	1
LG-7	nose gear axle-- 5"	\$22.23	Each	1
LG-7A	nose gear spacer, 5" fork	\$1.09	Each	1
LG-7B	nose gear axel assy.	\$28.40	Each	1
LG-200	nose gear fork assy. w/hdwr 6"			
LG-201	nose gear fork 6"	\$57.51	Each	1
LG-202	nose gear fork axle 6"	\$24.68	Each	1
LG-203	nose gear axle spacer 6"	\$32.01	Each	1
LG-204	nose gear axle assembly 6"	\$1.25		
LG-8	tail wheel assy. w/3" wheel	\$23.54	Each	1
LG-8A	tail wheel only, 3" x 1 1/4"	\$11.25	Each	1
LG-8B	tail wheel bushings only	\$6.29	Each	1
LG-10	tail wheel assy XL w/5" wheel			
LG-10A	tail wheel 5"			
TW-1L	tail wheel bracket, left side	\$5.96	Each	1
TW-1R	tail wheel bracket, right side	\$5.96	Each	1
<b>WHEELS &amp; TIRES, NOSE &amp; MAINS</b>				
1053-	wheel, 4" nylon	\$34.88	Each	
1057-	wheel, 5" nylon	\$46.96	Each	
1072-	wheel, 6" nylon	\$56.40	Each	
1125-	wheel, 6" aluminum (T-S)	\$64.08	Each	
1179-	wheel, 5" aluminum (T-S)	\$47.45	Each	
1214-	tire w/tube, 4"	\$35.84	Each	
1246-	tire w/tube, 5" (nylon & alum.)	\$42.00	Each	
1218-	tire w/tube, 6" (nylon wheel)( UL plane only)	\$47.96	Each	
1250-	tire w/tube, 6" aluminum (T-S)	\$49.85	Each	
7128-	tube only, 4"	\$12.30	Each	
7132-	tube only, 5"	\$11.52	Each	
7133-	tube only, 6" (410/350x6") (used with 6" wheel pants)	\$12.05	Each	
7014-	tire only, 4"	\$23.86	Each	
7168-	tire only, 5"	\$30.91	Each	
7018-2	tire only, 6" (1300x500x6) (used with 6" wheel pants)	\$40.51	Each	
8206-	wheel bearing, 5/8" precision	\$9.67	Each	

part number	description	Price	unit	Qty per A/C
<b>FIBERGLASS PARTS:</b>				
<b>Nose Cone</b>				
NC-100	nose cone, 1P w/hdwr	\$427.61	Each	1
NC-003	nose cone, 1P cone only	\$354.60	Each	1
NC-200	nose cone, 2P w/hdwr	\$494.21	Each	1
NC-004	nose cone, 2P cone only	\$421.20	Each	1
NC-001	nose cone pedal stop set	\$49.04	Each	1
NC-002	nose cone hdwr only	\$73.01	Each	1
NC-005	nose cone top angle plate	\$13.52	Each	1
NC-006	nose cone flat plates 6 x 11	\$8.33	Each	2
NC-100-K	nose cone retro kit, 1P. w/hdwr	\$551.80	Each	1
NC-200-K	nose cone retro kit, 2P. w/hdwr	\$551.80	Each	1
NC-200-L	nose cone longer style, 2P. cone only	\$457.00	Each	1
<b>3PC GAP COVER</b>				
FGC-100	fuselage gap cover, 3pcs. (503 engines)	\$365.40	SET	1
FGC-200	fuselage gap cover 2pcs (582 engines)	\$212.40	SET	1
FGC-001-F	fuselage gap cover, front section (503 & 582)	\$133.20	Each	1
FGC-001-M	fuselage gap cover, middle section (503)	\$54.00	Each	1
FGC-001-R	fuselage gap cover, rear section (503)	\$178.20	Each	1
FGC-003-M	fuselage gap cover, longer rear section (582)	\$79.20	Each	1
FGC-002	fuselage gap cover edging	\$2.57	FT.	11'
<b>WING TIPS</b>				
WT-001-L	fiberglass wing tip Left (requires BT-200)	\$181.80	Each	1
WT-001-R	fiberglass wing tip Right (requires BT-200)	\$181.80	Each	1
WT-R	fiberglass wing tip filler rib	\$6.59	Each	2
<b>GEAR LEGS</b>				
LSS-GLF-1	fiberglass gear leg fairings, specif left or right	\$106.26	Each	
LSS-GLF	fiberglass gear leg fairing set	\$212.52	Set	
<b>WHEEL PANTS</b>				
WP-5	wheel pant- 5"	\$136.80	Each	3
WP-500	wheel pant set, 5" (set of three w/hdwr)	\$516.29	Each	1
WP-6	wheel pant- 6"	\$151.20	Each	2
WP-600	wheel pant set, 6" (set of 2-6" & 1- 5" w/hdwr)	\$544.01	Each	1
WP-700	wheel pant set, 6" (set of 3-6" w/hdwr)	\$557.87	Each	1
WP-001	wheel pant hdwr only (new style)	\$24.31	Each	1
WP-001-OS	wheel pant hdwr only (old style)	\$24.31	Each	1
WP-002	wheel pant brkt (gear leg)(old style)	\$3.73	Each	2
WP-003	wheel pant spacer, nose (pvc)	\$1.37	Each	2
WP-004	wheel pant bolt, nose wheel	\$3.42	Each	1
WP-005	wheel pant clamp (old style)	\$7.24	Each	2
WP-006	wheel pant mounting plate, alum. (new style)	\$4.53	Each	2

part number	description	Price	unit	Qty per A/C
<b>BRAKE KITS AND RELATED HARDWARE:</b>				
BRK-100	brake set with axle assy.s, ( ) style	\$443.10	Set	1
BRK-HH	hegar hydraulic brakes with 6" alum. wheels & tires	\$1,130.75	Set	1
BRK-001	brake axle weldment, ( ) style-- discontinued			
BRK-002	brake drum, (fits left or right)	\$20.58	Each	2
BRK-003L	brake shoe plate, left side	\$56.34	Each	1
BRK-003R	brake shoe plate, right side	\$56.34	Each	1
BRK-004	brake shoe set, (2 sets per a/c) ( 4" )	\$19.01	Set	2
BRK-005	brake shoe plate spring-- old style	\$6.93	Each	2
BRK-006	brake cable set (w/handle)	\$76.87	Each	1
BRK-007	brake cable hand lever only	\$42.31	Each	1
BRK-008	brake cable only w/o housing	\$13.98	Each	2
BRK-009	brake cable w/housing	\$21.32	Each	2
BRK-010	brake cable bolt drilled w/nut	\$3.99	Each	2
BRK-011	brake bolt, STD (2 1/2" - SHCS)	\$0.48	Each	6
BRK-012	brake bolt, H-S (4"- SHCS)	\$2.27	Each	6
BRK-013	brake bolt, T-S (4 1/2"- SHCS)	\$3.19	Each	6
BRK-014	cable compression spring (2per set of brakes)( Old Style)	\$1.34	Each	2
BRK-015	brake cable housing only	\$12.28	Each	2
BRK-016	brake floater bushing	\$3.82	Each	6
BRK-017	brake lever cable retainer	\$5.08	Each	1
BRK-018	brake shoe spring	\$2.54	Each	2
BRK-019	brake actuator arm, specify left or right	\$1.56	Each	2
BRK-2387	brake cable adjustor bolt	\$3.08	Each	2
BRK-HGR	hegar hydraulic brake package w/ 6" alum. wheels	\$1,130.75	Each	
BRK-001-LSS	hegar axles w/ key & 5/8" nyloc nut	\$19.76	Each	
BRK-002-LSS	hegar 6" alum. wheel	\$98.95	Each	1
BRK-003-LSS	hegar 6" alum. wheel, front fork	\$120.95	Each	2
<b>DOOR KITS, DOOR PARTS, AND DOOR LEXAN:</b>				
DR-100	door kit, 1P (standard or cw) Clear lexan	\$430.65	Each	1
DR-100-T	door kit, 1P (standard or cw) Tinted lexan	\$546.32	Each	1
DR-101	wrap around windshield kit, 1P, Clear lexan	\$251.56	Each	1
DR-101-T	wrap around windshield kit, 1P Tinted lexan	\$378.61	Each	1
DR-200	door kit w/hdwr, 2P STD, Clear lexan	\$754.68	Each	1
DR-200-T	door kit w/hdwr, 2P STD., Tinted lexan	\$881.73	Each	1
DR-200X	door kit w/hdwr, 2P CW, Clear lexan	\$660.34	Each	1
DR-200X-T	door kit w/hdwr, 2P CW, Tinted lexan	\$787.39	Each	1
DR-201	wrap around windshield kit, 2P STD. Clear lexan	\$251.56	Each	1
DR-201-T	wrap around windshield kit, 2P STD. Tinted Lexan	\$378.61	Each	1
DR-201X	wrap around windshield kit, 2P CW Clear lexan	\$251.56	Each	1
DR-201X-T	wrap around windshield kit, 2P CW Tinted lexan	\$378.61	Each	1
DR-001	door hardware only, 2P	\$116.04	Each	1
D-001	door hinge w/pin	\$3.61	Each	4 - 6
D-001-A	door hinge pin only	\$1.09	Each	4 - 6
D-002	bungee hook (alum.)	\$2.25	Each	2

part number	description	Price	unit	Qty per A/C
D-003	door top center bracket (alum.)	\$2.25	Each	1
D-004	door open bracket (alum.) (old style)	\$2.25	Each	2
D-005	door open latch (nylon) (old style)	\$2.97	Each	2
D-004-L	door open folding support, left (new style)	\$8.29	Each	1
D-004-R	door open folding support, right (new style)	\$8.29	Each	1
D-004-L-A	door open folding support assy., left (new style)	\$16.82	Each	1
D-005-R-A	door open folding support assy., right (new style)	\$16.82	Each	1
D-006	door close latch (nylon)	\$2.97	Each	2
D-007	door bungee w/adel clamps	\$3.27	Each	2
D-TF	door top frame, 1P	\$26.53	Each	1
2D-TF	door top frame, 2P	\$38.88	Each	1
D-1-6L	door frame parts, 2P left undrilled (specify STD or CW)	\$72.86	Each	1
D-1-6R	door frame parts, 2P right undrilled (specify STD or CW)	\$72.86	Each	1
D-W1L	windshield frame bow,Lt(specify 1P,2P STD or 2P CW)	\$9.97	Each	1
D-W1R	windshield frame bow,Rt?(specify 1P,2P STD or 2P CW)	\$9.97	Each	1
DFT-1	door frame tube #1, 1P	\$7.66	Each	2
DFT-2	door frame tube #2, 1P	\$6.22	Each	2
DFT-3	door frame tube #3, 1P	\$6.96	Each	2
DFT-4	door frame tube #4, 1P	\$8.23	Each	2
2DFT-1	door frame tube #1, 2P	\$11.20	Each	2
2DFT-2	door frame tube #2, 2P	\$8.53	Each	2
2DFT-3	door frame tube #3, 2P	\$7.40	Each	2
2DFT-4	door frame tube #4, 2P	\$7.55	Each	2
2DFT-5	door frame tube #5, 2P- L5	\$7.14	Each	2
2DFT-6	door frame tube #6, 2P- L6	\$9.31	Each	2
DG-001	door gusset	\$2.25	Each	2
DG-002	door gusset	\$2.25	Each	4
DG-003	door gusset	\$2.25	Each	2
DG-004	door gusset	\$2.25	Each	2
DG-005	door gusset	\$2.25	Each	6
LX-TOP	lexan top frame cover, 1P (specify left or right)	\$10.67	Each	2
2LX-TOP	lexan top frame cover, 2P (specify left or right)	\$16.78	Each	2
<b>CUSHIONS,BELTS,SHOULDER HARNESS:</b>				
SB-1	seat belt --all models--	\$48.71	Each	1 - 2
SH-1	shoulder harness w/hdwr -- all models --	\$57.75	Each	1 - 2
SEAT-001	seat-sling bottom for UL			
The seat parts below are for the new style since 1997. Send photo for older models so we can match.				
SEAT-002	seat cover assembly	\$45.00	Each	1 or 2
SEAT-003	seat cushions- back & seat	\$21.78	Each	1 or 2
SEAT-004	seat cover assembly w/logo	\$85.00	Each	1 or 2
<b>SAILCLOTH WING COVERING</b>				
GSLS-1CH	wing sail set, 1P (Dacron, specify color)	\$1,683.00	Each	1
GSLS-2CH	wing sail set, 2P (Dacron, specify color)	\$1,715.00	Each	1

part number	description	Price	unit	Qty per A/C
<b>STITS FABRIC-WINGS, FUSELAGE, &amp; TAIL</b>				
ST-100	pre-cut fuselage fabric, 1P	\$170.64	Set	1
ST-101	bottom piece, 1P	\$36.81	Each	1
ST-102	left or right rear piece, 1P	\$49.72	Each	2
ST-103	left or right front piece, 1P	\$40.50	Each	2
ST-104	top of nose piece, 1P	\$9.14	Each	1
ST-200	pre-cut fuselage fabric, 2P	\$184.02	Set	1
ST-201	bottom piece, 2P	\$46.02	Each	1
ST-202	left or right rear piece, 2P	\$52.21	Each	2
ST-203	left or right front piece, 2P	\$46.02	Each	2
ST-204	top of nose piece, 2P	\$11.00	Each	1
ST-300	pre-sewn tail sock set, less dorsal fin	\$227.03	Set	1
ST-300-LS	tail fabric set, light sport plane only, less dorsal fin	\$277.62	Set	1
ST-300-CS	tail fabric set, New style (XL,XS), less dorsal fin	\$260.29	Set	1
ST-300-UK	tail fabric set, UK, less dorsal fin	\$290.49	Set	1
ST-301	stab sock	\$48.90	Each	2
ST-302	elevator sock	\$44.19	Each	2
ST-303	rudder sock	\$44.19	Each	1
ST-303-LS	rudder fabric, pre-cut--light sport plane only--	\$50.50	Each	1
ST-303-UK	rudder sock, UK ( taller version of Std. rud. )	\$53.04	Each	1
ST-300-CS	rudder sock, XS/XL style	\$49.05	Each	1
ST-304	vertical fin sock	\$44.19	Each	1
ST-304-LS	vertical fin fabric, pre-cut-- light sport plane only--	\$55.74	Each	1
ST-304-UK	vertical fin sock, UK ( taller version of Std. v. fin )	\$53.04	Each	1
ST-304-CS	vertical fin sock, XS/XL style	\$55.74	Each	1
ST-305	dorsal fin sock	\$24.07	Each	1
ST-305-UK	dorsal fin sock, UK ( taller version of Std. d. fin )	\$27.54	Each	1
ST-306	aileron fabric- pre-cut	\$46.88	Each	2
ST-400	wing fabric 1P & 2P STD. (both wings)	\$254.91	Set	1
ST-400X	wing fabric 1P & 2P CW (both wings)	\$238.14	Set	1
SF-104X	1.8oz fabric	\$17.95	YD.	
ST-RT	3/4" reinforcing tape	\$45.20	Each	1
ST-ST	2" seam tape (50yds)	\$45.99	Each	1
PT-QT	Poly-Tak cement, quart (Drop ship only)	\$0.00	Each	1
MEK-QT	MEK, quart (Drop ship only)	\$0.00	Each	1
SF-104X	1.8 oz. aircraft fabric 70" wide	\$17.95	YD.	
<b>MOTOR MOUNTS KITS:</b>				
MM-100	motor mount Basic Kit		Each	1
MM-001	motor Lord mount Kit w/hdwr 503		Each	1
MM-002	motor Lord mount Kit w/hdwr 582		Each	1
MM-003	motor mount plate 503/582		Each	1
MM-004	motor mount hdwr only 503		Each	1
MM-005	motor mount hdwr only 582			
MM-1	motor mount angles		Each	2
MM-2	motor mount spacers		Each	2

part number	description	Price	unit	Qty per A/C
MM-3	motor mount lord mounts	\$14.75	Each	6 - 8
<b>EXHAUST AND PARTS:</b>				
MFB-503	muffler bracket w/hdwr (503)	\$112.74	Each	1
MFB-447	muffler bracket w/hdwr (447)	\$112.74	Each	1
MFB-004	muffler brkt. hdwr set (rotax)	\$14.82	Set	1
MFB-005	muffler rubber grommet set	\$5.31	Set	1
M8X35	8x35 bolt(muffler mount/rotax head bolt)	\$1.53	Each	2
8316-	muffler grommet, female	\$0.70	Each	2
9406-	muffler grommet, male	\$2.28	Each	2
MFB-582	muffler bracket w/hdwr (582)	\$173.25	Each	1
<b>REDUCTION DRIVE &amp; PARTS</b>				
HTD-100R	Reduction Drive Rotax, complete w/belt	\$1,617.00	Each	1
HTD-001	drive top pulley w/bearings ( 78 teeth )	\$395.00	Each	1
HTD-002	drive top pulley bearing	\$27.72	Each	4
HTD-003	drive top pulley snap ring	\$3.36	Each	2
HTD-004	drive top pulley shaft	\$68.15	Each	1
HTD-005	drive thrust spacer (top pulley)	\$31.19	Each	1
HTD-006	drive, prop hub 75MM-5/16"	\$85.70	Each	1
HTD-007	drive, prop hub mounting bolt	\$0.58	Each	6
HTD-008	drive, prop plate 75mm-5/16"	\$22.76	Each	1
HTD-009A	drive, bottom pulley, New Style 30 teeth ( bolt on rings )	\$287.75	Each	1
HTD-009-B	drive, bottom pulley ring (bolt on)	\$26.22	Each	2
HTD-010	drive bottom pulley bolt	\$2.08	Each	1
HTD-011	drive, thick washer (bottom pulley)	\$15.60	Each	1
HTD-012	drive, adjustor bracket	\$42.74	Each	1
HTD-013	drive, adjustor brkt. bolt	\$0.48	Each	1
HTD-014	drive, 3/8 jam nut (adj.brkt.)	\$0.18	Each	1
HTD-015R-NS	drive tower, Rotax 447/503, w/spacer incorprated(08/02)	\$335.42	Each	1
HTD-016R	drive tower mount bolt, 447/503	\$1.14	Each	8
HTD-018	drive tower, Rotax 277	\$259.18	Each	1
HTD-019	drive tower mount bolt, 277	\$0.99	Each	4
HTD-020	drive, prop bolt 5/16 x 3 1/4	\$5.08	Each	6
HTD-021	drive, prop bolts - set of 6	\$48.60	Each	1
HTD-022	exhaust clamps, LSS ( set of 2)	\$132.83	Set	1
HTD-1-12	1"-12 castle nut, grade 5 zinc (shaft)	\$12.38	Each	1
HTD-640	Cog belt (Rotax 2.1/1 drives)	\$112.62	Each	1
HTD-720-GT-2	Cog belt (Rotax 2.2/1 drives)	\$124.17	Each	1
HTD-800	Cog belt (Hirth 2.2/1 drives)	\$88.94	Each	1
HTD-920	Cog Belt (some 1994 Rotax drives)	\$120.70	Each	1
HTD-960-GT3	Cog belt (Rotax 2.6/1 drive, produced after 1994/95)	\$129.70	Each	1
<b>STARTERS:</b>				
GPL	electric starter-- 582 only--	\$1,170.70	Each	
QCU-STARTER	electric starter -- 447 & 503 only --	\$814.28	Each	

part number	description	Price	unit	Qty per A/C
	<b>PARTS LISTED BELOW ARE FOR QCU STARTER ONLY</b>			
SMB-100	starter motor mount bracket	\$153.85	Each	1
SM-748	starter motor, QCU STARTER ONLY	\$149.95	Each	1
M8x1.25x80mm	bolt, flat head, countersunk, socket cap	\$13.06	Each	3
2"x3/8x16	bolt, hex head, grade 8	\$6.22	Each	2
GL-4-24	grounding lead, 4 gauge, 24"	\$7.90	Each	2
PL-4-11	power lead, 4 gauge, 11' red	\$43.45	Each	1
866 080	rectifier / regulator	\$80.80	Each	1
NGK-B8ES	spark plug	\$5.87	Each	2
PL-4-3	power lead, 4 gauge, 3' red	\$13.85	Each	1
CC-R	insulated cable end caps, red	\$3.85	Each	4
CC-B	insulated cable end caps, black	\$3.85	Each	2
FH-001	fuse holder, less fuse (15amp)	\$5.20	Each	1
SFW-001	starter fly wheel gear, large	\$103.95	Each	1
12-120	solenoid	\$53.13	Each	1
866 080	rectifier / regulator	\$80.80	Each	1
516-8MM	copper lugs	\$1.98	Each	8
68-7800	starter brush's ( qcu starter )	\$17.91	Each	1
<b>INSTRUMENTS:</b>				
TACH-T	tachometer, digital- Tini Tach (dash mount)	\$85.47	Each	1
IN-1	Instrument Panel, wood 1pl w/hrdwr	\$16.76	Each	1
IN-2	Instrument Panel, wood 2pl w/hrdwr	\$18.22	Each	1
IN-1A	Instrument Panel hardware only			
IN-3	instrument panel ,alum XL w/hrdwr	\$173.25	Each	1
IN-3A	Instrument panel XL hardware only			
IN-4	Instrument panel, alum XL w/ ESI cutout w/hrdwr			
IN-5	Instrument panel, alum XL blank			
IGN-SWITCH	ignition switch w/ start position	\$195.50	Each	1
IGN-WIRE	ignition switch wire w/connectors			
QCU-FG	fuel gauge with sender, 24" bendable		Each	1
QCU-FG-G	fuel gauge only, 5V input		Each	1
QCU-FG-S	fuel gauge sender only, 24" bendable		Each	1
QCU-FG-XL	dual fuel gauge w / sender, 12" bendable ( wing tanks)		Each	1
QCU-FG-G-XL	dual fuel gauge only, 5V input (wing tanks)		Each	1
QCU-FG-S-XL	fuel gauge sender only,12"bendable,5V output(wing tanks)		Each	2
QCU-GAS-XL	gascolator / filter w/ quick drain	\$177.71	Each	1
QCU-EXTEN	extension cable,4 conductor, 8'	\$19.00	Each	1
QCU-EXTEN-10	extension cable,4 conductor, 10'	\$26.27	Each	1
<b>AN HARDWARE:</b>				
AN3-5	Bolt, 3/16"	\$0.65	Each	
AN3-6A	bolt, 3/16"	\$0.33	Each	
AN3-7A	bolt, 3/16" (pedal control horn)	\$0.14	Each	
AN3-10	bolt, 3/16" (double ail. pulley)	\$0.61	Each	0 - 2
AN3-14A	bolt, 3/16" (stab fin mod)(nose fork)	\$0.53	Each	4
AN3-16	bolt, 3/16" (elev. bellcrank)	\$0.81	Each	2 - 2
AN3-17	bolt, 3/16" (cont. stick to turnbuckle)	\$0.85	Each	1 - 2

part number	description	Price	unit	Qty per A/C
AN3-23A	bolt 3/16" (rear wing strut bracket)	\$0.74	Each	4 - 4
AN3-24A	bolt 3/16" (front wing strut bracket)	\$0.77	Each	6 - 8
AN3-26A	bolt 3/16" (starter, fly wheel to bottom pulley)	\$0.77	Each	6
AN3-36	bolt 3/16" (rudder cable to pedal)	\$4.72	Each	2 - 2
AN4-4A	bolt, 1/4" (wheel pants, brakes)	\$0.54	Each	8
AN4-7	bolt (ail. & idler pulleys)	\$0.67	Each	5 - 8
AN4-7A	bolt (ball joints)	\$0.67	Each	8 - 12
AN4-10A	bolt (axle weldment w/wheel pants)	\$0.47	Each	2 - 2
AN4-14	bolt (stab attach bracket)	\$0.98	Each	5 - 5
AN4-14A	bolt, 1/4"	\$0.59	Each	2 - 8
AN4-15A	bolt (stab brackets to vertical fin)	\$0.59	Each	2 - 2
AN4-16	bolt (controls, thru ss u-bracket)	\$1.10	Each	5 - 8
AN4-16A	bolt (1" rony, lord mounts)(DT)	\$1.04	Each	7 - 19
AN4-17A	bolt (bottom landing gear leg)	\$0.67	Each	2 - 2
AN4-20	bolt (controls)	\$0.94	Each	0 - 2
AN4-20A	bolt (top landing gear leg)	\$0.70	Each	3 - 3
AN4-22	bolt ( replaced by AN4-23 for strut u-brkt's.)	\$1.24	Each	4 - 6
AN4-23	bolt (strut to fuselage u-brkt) ( replaces AN4-22)	\$1.47	Each	4 - 4
AN4-24A	bolt (strut to fuselage u-brackets)(drag cable)	\$1.45	Each	12 - 16
AN4-25	bolt (flaperons)	\$1.76	Each	3 - 3
AN4-26	bolt (wing spar to fuselage u-bracket)	\$1.82	Each	4 - 4
AN4-26A	bolt (u-brkt to root tube)	\$1.78	Each	2 - 2
AN4-27A	bolt	\$1.49	Each	
AN4-36	bolt (aileron bellcrank)	\$3.05	Each	1 - 1
AN5-25A	bolt (shoulder harness attach)	\$1.31	Each	1 - 2
AN5-50A	bolt (DT to root tube)	\$11.74	Each	4 - 5
AN5-52	bolt (2P rear pedals)	\$16.10	Each	0 - 2
AN5-52A	bolt (motor mount-root)	\$15.66	Each	3 - 3
AN525-832R10	bolt, screw type (lord mounts)	\$0.27	Each	32 - 32
AN525-10R10	bolt, screw type (heel cup)	\$0.28	Each	8 - 12
AN525-10R14	bolt, screw type (thru UB's)	\$0.37	Each	17 - 17
AN525-10R16	bolt, screw type (jury strut)	\$0.41	Each	2 - 2
AN525-10R20	bolt, screw type (EMP-7)	\$0.55	Each	10 - 10
AN525-10R24	bolt, screw type (FG-W1A)(DT)	\$0.61	Each	20 - 21
AN43B-14A	eyebolt (vert. fin)	\$16.06	Each	1 - 1
AN43B-24A	eyebolt (drag cables)	\$25.77	Each	2 - 2
AN365-832	nut, 5/32" nyloc (lord mount)	\$0.35	Each	32 - 32
AN365-1032	nut, 3/16" nyloc (screw bolt)	\$0.24	Each	57 - 72
AN365-428	nut, 1/4" nyloc	\$0.30	Each	28 - 42
AN365-524	nut, 5/16" nyloc	\$0.40	Each	9 - 10
AN363-428	nut, 1/4" hi temp lock nut	\$0.61	Each	1 - 3
AN316-4	nut, 1/4" jam (ball joints)	\$0.51	Each	4 - 4
AN364-428	nut, 1/4" thin nyloc	\$0.30	Each	2 - 4
AN310-3	nut, 3/16" castle	\$0.91	Each	3 - 6
AN310-4	nut, 1/4" castle	\$1.64	Each	18 - 23
AN310-5	nut, 5/16" castle	\$1.28	Each	0 - 2



part number	description	Price	unit	Qty per A/C
AN960-10	washer, AN 3/16"	\$0.24	Each	12 - 16
AN960-416	washer, AN 1/4"	\$0.09	Each	20 - 42
AN960-516	washer, AN 5/16"	\$0.10	Each	2 - 2
AN960-816	washer, AN (frt. rudder pedal)	\$0.25	Each	2 - 4
AN960-1016	washer, AN 5/8" (LG-2'S)	\$0.30	Each	8 - 8
AN960-1616	washer, 1" AN (drive shaft)	\$0.81	Each	1
AN970-3	washer, 3/16 large area, stab fin mod	\$0.31	Each	
AN970-4	washer, 1/4" large area	\$0.52	Each	
AN970-5	washer, 5/16" large area	\$0.51	Each	2 - 4
AN100-C3	thimble (control & drag cable)	\$0.65	Each	18 - 20
AN115-21	shackle (rudder & ail. cable)	\$17.19	Each	10 - 4
AN393-13	clevis pin	\$1.29	Each	14 - 20
AN393-19	clevis pin	\$0.77	Each	10 - 10
AN416-2	safety pin (clevis & castle)	\$0.89	Each	27 - 34
AN742D-3	adel clamp (nylaflow)	\$0.61	Each	10 - 17
AN742D-4	adel clamp ( 2P throttle interconnect)	\$0.85	Each	0 - 2
AN380-2-4	cotter pin (castle nut)	\$0.06	Each	27 - 28
AN130-8S	turn buckle (rudder cable)	\$67.86	Each	2 - 2
AN140-8S	turn buckle (aileron cable)	\$65.34	Each	2 - 4
AN111-3	bushing (throttle cable)	\$2.37	Each	1 - 1
AN490-HT8P	rod end (aileron & flaperon pushrod)	\$18.61	Each	3 - 3
<b>CHALLENGER DECALS ETC. :</b>				
DEC-L	decal- large (Challenger) 24"	\$16.20	Each	
DEC-S	decal- small (Challenger) 12" two supplied w/each kit	\$10.80	Each	2
DEC-M	decal-mini (Challenger Pilot) 6"	\$5.40	Each	
DEC-EXP	decal-EXPERIMENTAL 2" x 24"	\$5.40	Each	
HAT	Challenger ball cap, when available		Each	1
<b>HARDWARE KITS</b>				
SS-LR	spar & strut hdwr, less Ronys	\$31.02	Each	1
SS-LR-HL	spar & strut hdwr, less Ronys w/ heavy load saddle kit	\$31.02	Each	1
S1-HDWR	Sect.I HDWR Bag	\$200.40	Each	1
S1-HDWR-BN	Sect.I HDWR ONLY (bolts, nuts, etc.)	\$40.81	Each	1
S1-RONY-BN	Sect.I RONY HDWR(bolts,nuts,etc.),rony not included	\$23.24	Each	1
S2-HDWR	Sect.II HDWR Bag	\$153.48	Each	1
SF-HDWR	Superflite HDWR Bag, 2P. STD. only	\$297.40	Each	1
SP-SM	Spares kit-small	\$18.79		
SP-MD	Spares kit-medium	\$53.84		
SP-LG	Spares kit-large	\$105.53		
HL-100	Heavy load saddle kit	\$92.03	Set	1
HNG-100	hinge assy. complete	\$12.34	Each	6
<b>SPECIAL ULTRALIGHT TYPE HARDWARE:</b>				
HL-101	saddle square aluminum ( fits 2" dia. tube w/ 1/4" hole)	\$14.40	Each	4
HL-102	saddle round aluminum ( fits 2" dia. tube w/ 1/4" hole)	\$12.60	Each	4

part number	description	Price	unit	Qty per A/C
ST-16F	stainless flat tang (1P rudder pedal, CW style jury struts)	\$1.25	Each	16
ST-16L	stainless L-bracket (elev/rud hinge, CW style jury struts)	\$2.18	Each	44
PW-4	washer, nylon (stab bracket spacer)(black)	\$0.41	Each	4
LSR	lg. safety ring (tail hinge)	\$1.46	Each	8
T2-FAT	stainless tang (drag cables)	\$2.26	Each	2
WP-23	nylon wear strip (fuselage cross tubes)	\$1.91	Each	2
3246-	clevis fork, alum. (control pushrods)	\$6.55	Each	10 - 6
3675-	poly tip (wing rib stays)	\$0.74	Each	44
3742-	u-bracket, S.S. (control stick)	\$7.03	Each	5 - 10
4119-	end cap, 2" sq. (root tube)	\$6.29	Each	1
4350-	saddle, nylon 1" x 5/16" hole (down tubes)	\$2.70	Each	27 - 32
4352-	saddle, nylon 1" x 1/4" (controls)	\$3.36	Each	12 - 20
4365-	tubing connector (FB-11 & FB-10)	\$3.36	Each	3
4372-	threaded insert (FB-11 & FB-10)	\$3.19	Each	2
EC-1	end cap 1" (control stick, DT1, FB10)	\$0.94	Each	4 - 5
EC-7	end cap 1 5/8" (outer lift strut)	\$1.28	Each	4
EC-9	end cap 1 7/8" (rear of longeron)	\$1.42	Each	2
S-84	1 5/8" saddle (lift strut)	\$1.41	Each	8
SOS-1	lexan spacer (aileron bellcrank)	\$1.52	Each	2
CS-84	bellcrank, aileron control	\$10.40	Each	2
CS-84D	bellcrank, differential (aileron)	\$14.96	Each	2
SS-EB	bellcrank, elevator control (elev. prod/FB11)	\$7.94	Each	2
CP-5	bushing, plastic (cable-pedal)	\$1.38	Each	
936-	White nylon pulley (idler pulley)	\$4.54	Each	1
RONY-1	u-bracket anodized alum. 1" (CT's)	\$27.10	Each	4 - 8
RONY-158	u-bracket anodized alum. 1 5/8" (lower lift strut atch brkt.)	\$27.10	Each	4
RONY-2	u-bracket anodized alum. 2" (wing spar attach brkt.)	\$27.10	Each	4
RONY-78	u-bracket anodized alum. 7/8" (stab attach brkt.)	\$27.10	Each	4
<b>( Rony brackets are black anodized 7075-T6 aluminum)</b>				
<b>RIVETS:</b>				
				per 100
SSD42SSBS	1/8 stainless steel rivet (short) = 1/8" grip-typical	\$0.15	Each	9 - 12
SSD44SSBS	1/8 stainless steel rivet (long) = 1/4" grip-typical	\$0.17	Each	5 - 7
SSD52SSBS	5/32 stainless steel rivet replaces oversize 1/8 holes	\$0.37	Each	
SSD54SSBS	5/32 stainless steel rivets replaces oversize 1/8 holes	\$0.37	Each	
SSD62SSBS	3/16 Stainless steel rivet(short) = 1/8" grip-typical	\$0.18	Each	
SSD64SSBS	3/16 Stainless steel rivet(short) = 1/4" grip-typical	\$0.20	Each	
AD42ABS	1/8" aluminum rivet (short)	\$0.06	Each	5
AD44ABS	1/8" aluminum rivet (long)	\$0.06	Each	5
AD42ABSLF	1/8" aluminum large flange rib rivet(for fabric wing)	\$0.12	Each	3 - 4
AD62ABS	3/16" aluminum rivet (for CW style jury struts)	\$0.14	Each	1
AD64ABS	3/16" aluminum rivet (tail hinges & CW style jury struts)	\$0.11	Each	1 - 1.3
<b>MISCELLANEOUS HARDWARE:</b>				
LAW-112	washer, 1/4 x 1 1/2" SS	\$0.47	Each	14
LAW-114	washer, 1/4 x 1 1/4" SS	\$0.47	Each	3 - 6

part number	description	Price	unit	Qty per A/C
2361-	wire swivel (throttle)	\$0.94	Each	0 - 2
FW-25	washer, zinc 1/4"	\$0.09	Each	5 - 6
FW-516	washer, zinc 5/16" (DT-RT)	\$0.11	Each	8 - 14
LG-CPIN	cotter pin, zinc 1/8" (drive)	\$0.33	Each	1 - 3
D6102	never kinks (gear leg drag cable)	\$1.21	Each	4
WNW-25	washer white nylon 1/4" (flaperons)	\$0.18	Each	14
S-10	heel cups (rudder pedals)	\$8.09	Each	2 - 4
SAE-75	bolt, 1/4x28x3/4, grade 8 (lg-2') --discounted 4/97 --	\$0.26	Each	
SAE-1.5	bolt, 1/4x28x1 1/2 (hirth muffler)	\$0.70	Each	
SAE-2	bolt, 1/4x28x2 (tail & muffler bracket)	\$0.75	Each	3
SAE-2-13	bolt, 1/2x13x2 (hirth motor mount plate)	\$1.35	Each	
HC-114	s.s. hose clamp (nose gear carrier)	\$1.49	Each	2
HC-34	s.s. hose clamp (nose gear carrier)	\$1.49	Each	2
HC-FL	s.s. hose clamp (fuel line)	\$1.14	Each	12
M10X40	sckt head cap bolt (hirth 2.2/1 reduction tower)	\$0.98	Each	
LW-12	washer, 1/2" lock type	\$0.14	Each	2 - 4
SNAP-B	snap button	\$0.20	Each	2 - 4
SNAP-F	snap, female socket	\$0.20	Each	2 - 4
SNAP-M	snap, male	\$0.17	Each	2 - 4
3/8-24 x 7"	grade 8 bolt ( new nose fork )	\$4.41	Each	1
3/8-24	nyloc nut ( new nose fork bolt)	\$0.23	Each	1
3306S	nylon fuel line clamp	\$0.15	Each	
28-1-C	nico-press ( 1/16 control cable)	\$0.41	Each	20 - 28
28-2-G	nico-press ( 3/32 drag cable)	\$0.58	Each	8 - 8
28-3-M	nico-press ( 1/8 gear leg cable)	\$0.85	Each	8 - 8
NF-4	ball joint (control pushrods)	\$9.98	Each	7 - 7
NF-400	ball joint assy. (w/nut, bolt, washers & etc..)	\$11.22	Each	
2700-	cable bushing aluminum (landing gear cables)	\$2.18	Each	4 - 4
QCU-PUL	Pulley- Aileron Cables Phenolic	\$34.74	Each	8
2322-	cable housing (2P throttle interconnect)	\$3.19	FT.	

# KITPLANES

## ShopSheet

By Ron Wanttaja

# Bolt Nomenclature

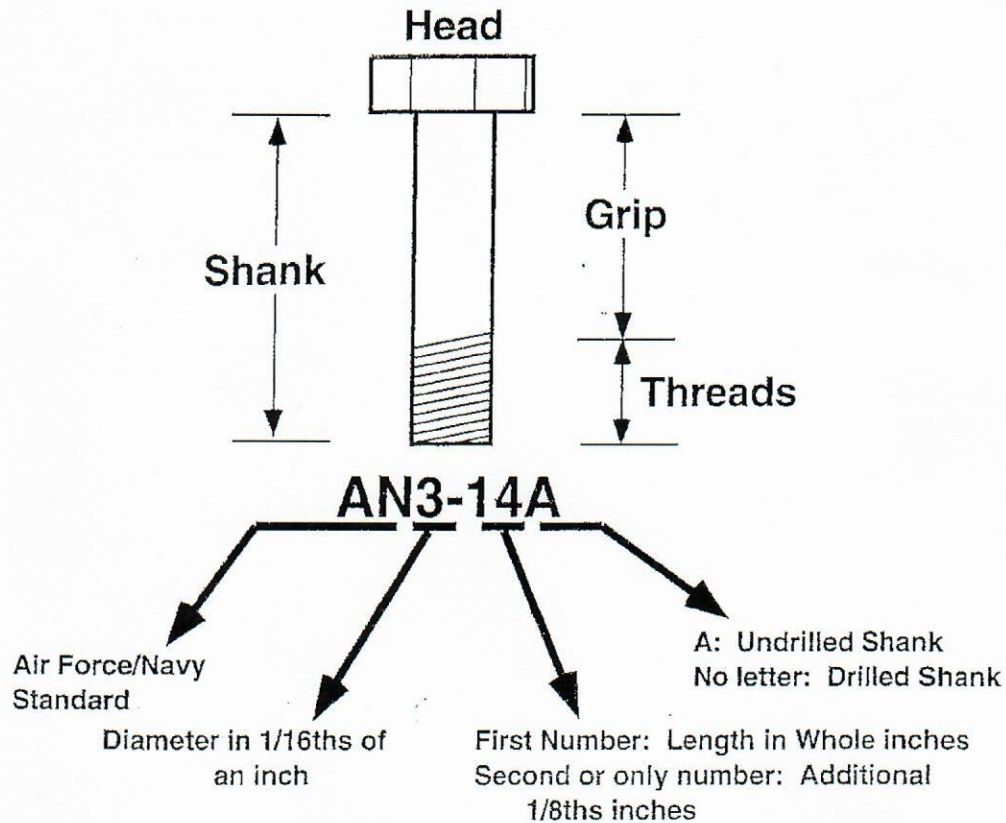

### APPROXIMATE GRIP LENGTH

Dash Number	AN3	AN4	AN5	AN6	AN7	AN8
3	1/16	1/16	-	-	-	-
4	1/8	1/16	1/16	-	-	-
5	1/4	3/16	3/16	1/16	1/16	-
6	3/8	5/16	5/16	3/16	3/16	1/16
7	1/2	7/16	7/16	5/16	5/16	3/16
10	5/8	9/16	9/16	7/16	7/16	5/16
11	3/4	11/16	11/16	9/16	9/16	7/16
12	7/8	13/16	13/16	11/16	11/16	9/16
13	1	15/16	15/16	13/16	13/16	11/16
14	1 1/8	1 1/16	1 1/16	15/16	15/16	13/16
15	1 1/4	1 3/16	1 3/16	1 1/16	1 1/16	15/16
16	1 3/8	1 5/16	1 5/16	1 3/16	1 3/16	1 1/16
17	1 1/2	1 7/16	1 7/16	1 5/16	1 5/16	1 3/16
20	1 5/8	1 9/16	1 9/16	1 7/16	1 7/16	1 5/16
21	1 3/4	1 11/16	1 11/16	1 9/16	1 9/16	1 7/16
22	1 7/8	1 13/16	1 13/16	1 11/16	1 11/16	1 9/16
23	2	1 15/16	1 15/16	1 13/16	1 13/16	1 11/16
24	2 1/8	2 1/16	2 1/16	1 15/16	1 15/16	1 13/16
25	2 1/4	2 3/16	2 3/16	2 1/16	2 1/16	1 15/16
26	2 3/8	2 5/16	2 5/16	2 3/16	2 3/16	2 1/16
27	2 1/2	2 7/16	2 7/16	2 5/16	2 5/16	2 3/16
30	2 5/8	2 9/16	2 9/16	2 7/16	2 7/16	2 5/16

# Challenger nose gear assembly NG-100 (Less fork)

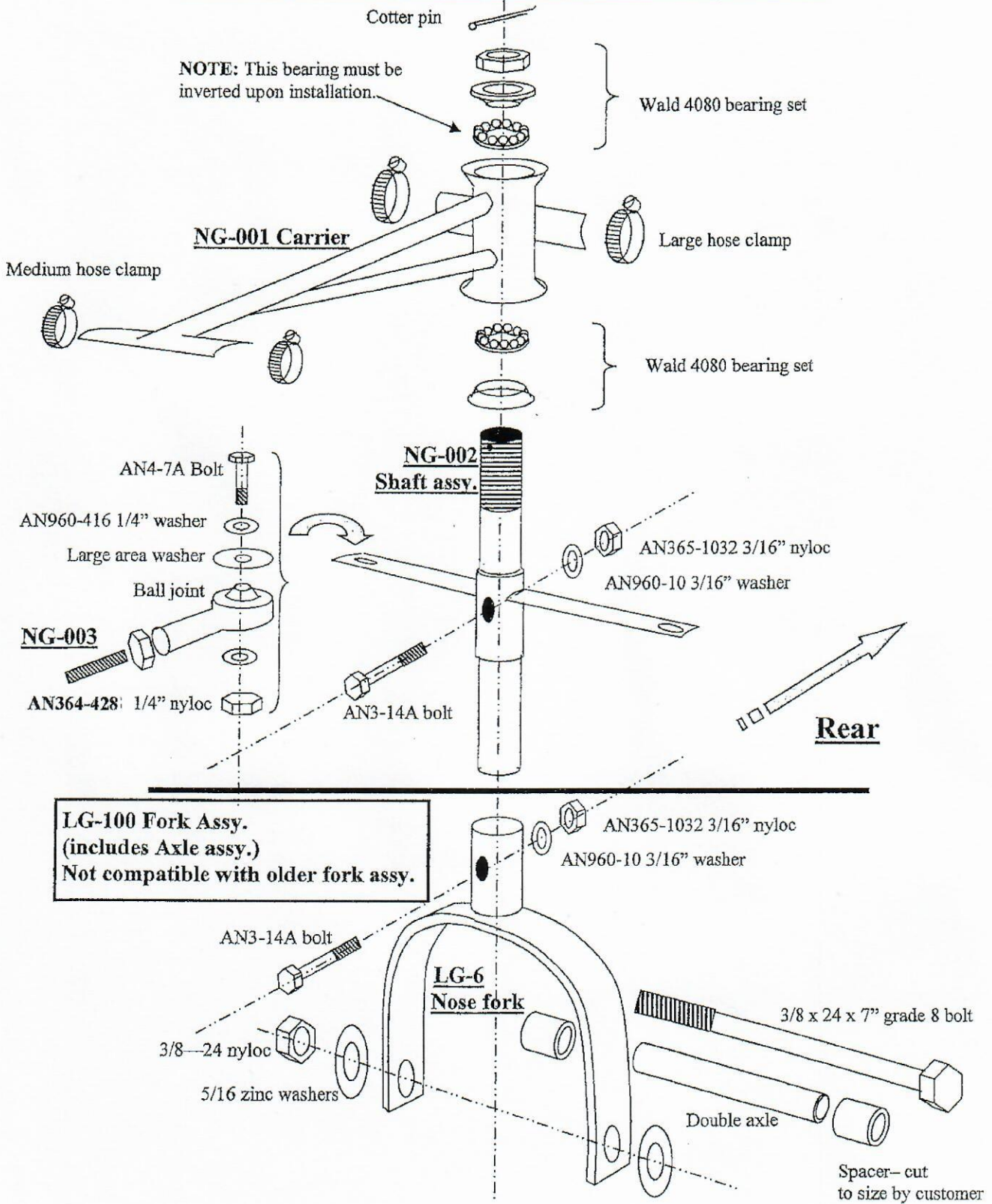

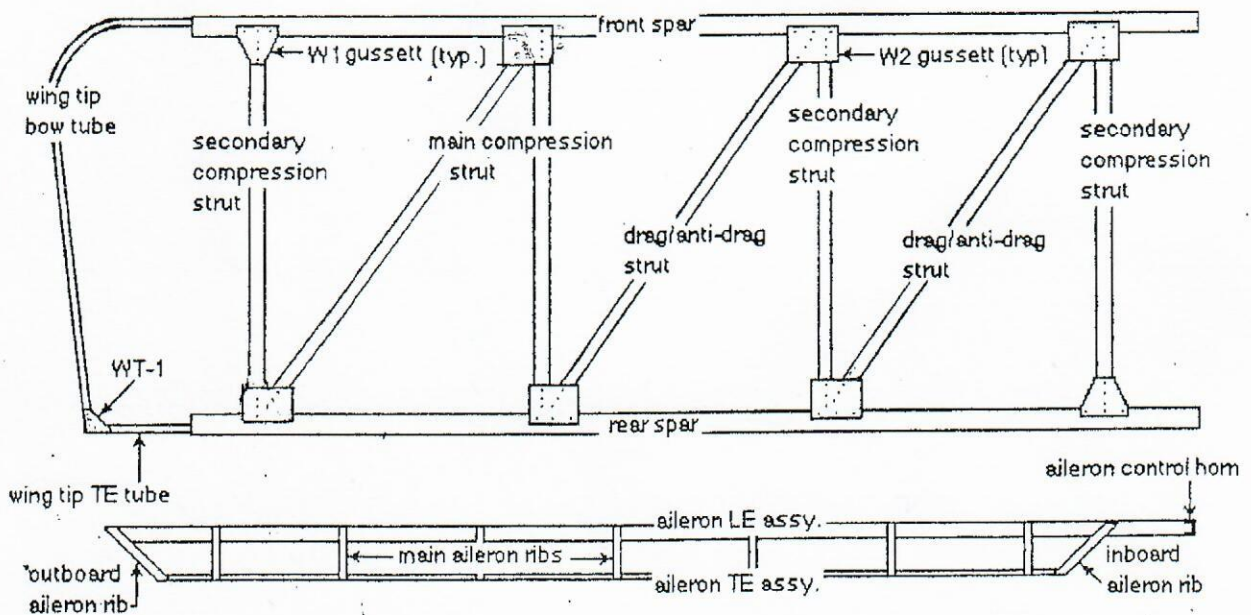
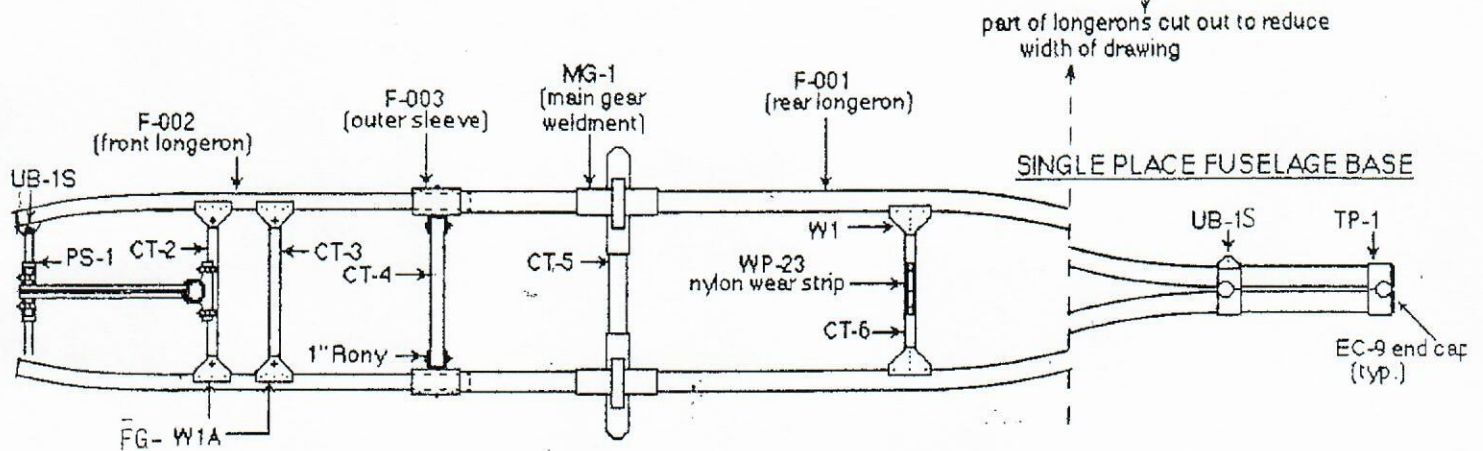
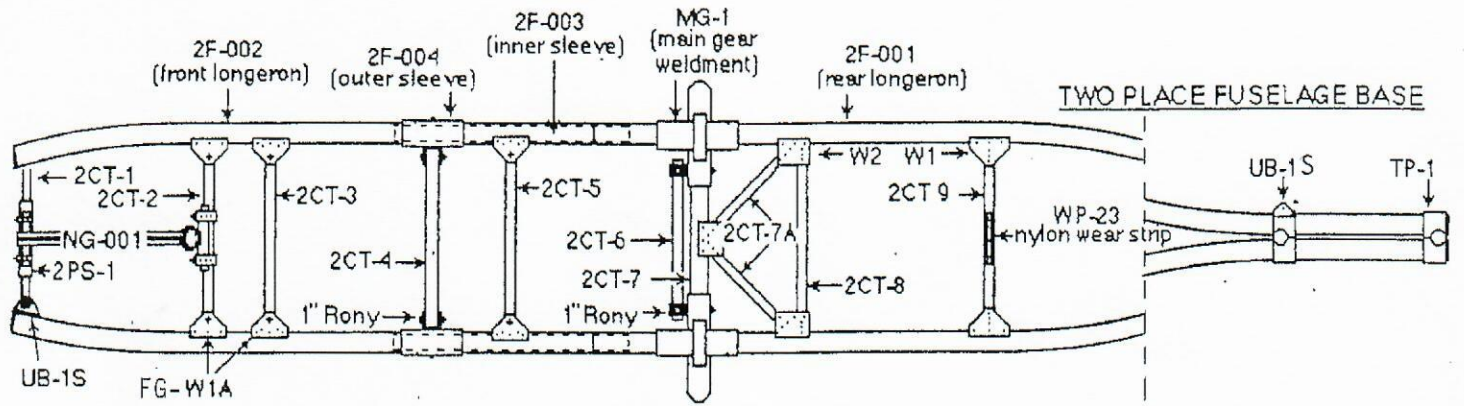

Wing drawing not-to scale - for location of parts only. Clipped wing shown; long wing similar. Standard wings built before 1991 will have fewer compression and drag struts than shown.



# Challenger I

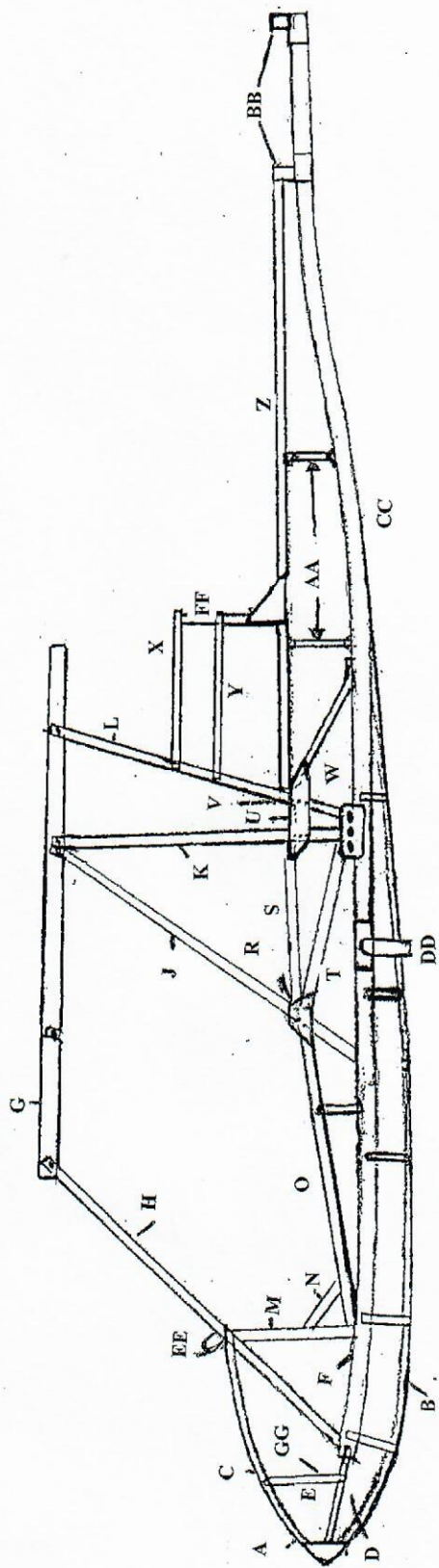

PART#	DESCRIPTION	PART#	DESCRIPTION
A =	Top Stringer	T =	Fuselage brace
B =	Stringer Bottom	U =	" "
C =	Nose Spreader **	V =	" "
D =	Stringer Brace	W =	" "
E =	Stringer Upright	X =	Rear former tube, top, left or right
F =	Front longeron assy.	Y =	Rear former tube, bottom, left or right
G =	Root tube, main beam	Z =	Rear boom tube
H =	Down tube #1	AA =	Fuselage brace
J =	Down tube #2	BB =	Tail post weldment
K =	Down tube #3	CC =	Rear longeron
L =	Down tube #4	DD =	Main gear weldment
M =	Fuselage brace	EE =	Windshield former
N =	" "	FF =	Rear former upright
O =	" "	GG =	Pedal stop tube **
R =	" "		
S =	" "		
		FB-5	Fuselage brace
		FB-6	" "
		FB-9	" "
		FB-7	" "
		FB-19T	Rear former tube, top, left or right
		FB-19B	Rear former tube, bottom, left or right
		FB-11	Rear boom tube
		FB-12	Fuselage brace
		TP-1	Tail post weldment
		F-001	Rear longeron
		MG-1	Main gear weldment
		FWF-1	Windshield former
		FB-10	Rear former upright
		FB-16	Pedal stop tube **

Items marked with \*\* are not shown



# Challenger I

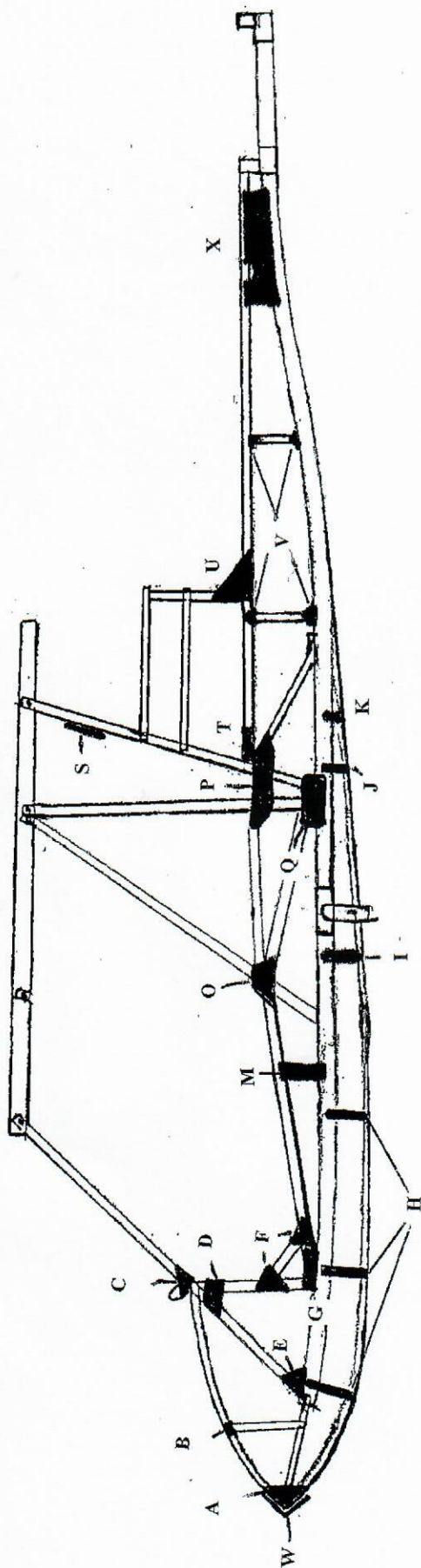

PART #	DESCRIPTION	PART #	DESCRIPTION
A= NG-1	Nose gusset	O= FG-1	Cluster gusset
B= FG-10	Spreader gusset	P= FG-2	Cluster gusset
C= FG-6	Windshield gusset	Q= FG-3	Downtube gusset
D= FG-7	Triangle gusset	S= AM-1	Idler pulley plate
E= FG-4	DT-1 gusset ( L or R )	T= FG-12	T-bar gusset ( top or bottom )
F= EMP-3	Triangle gusset	U= FG-9	T-bar gusset fairing
G= FG-5	Channel gusset	V= UB-2	S.S. U-brkt.
H= FSR-6	Stringer rib	W= FG-11	Nose plate
I= FSR-5	Stringer rib	X= FG-99	Rear boom brace gusset
J= FSR-4	Stringer rib		
K= FSR-2	Stringer rib		
M= FCR-2	Cockpit rib		

# Challenger II

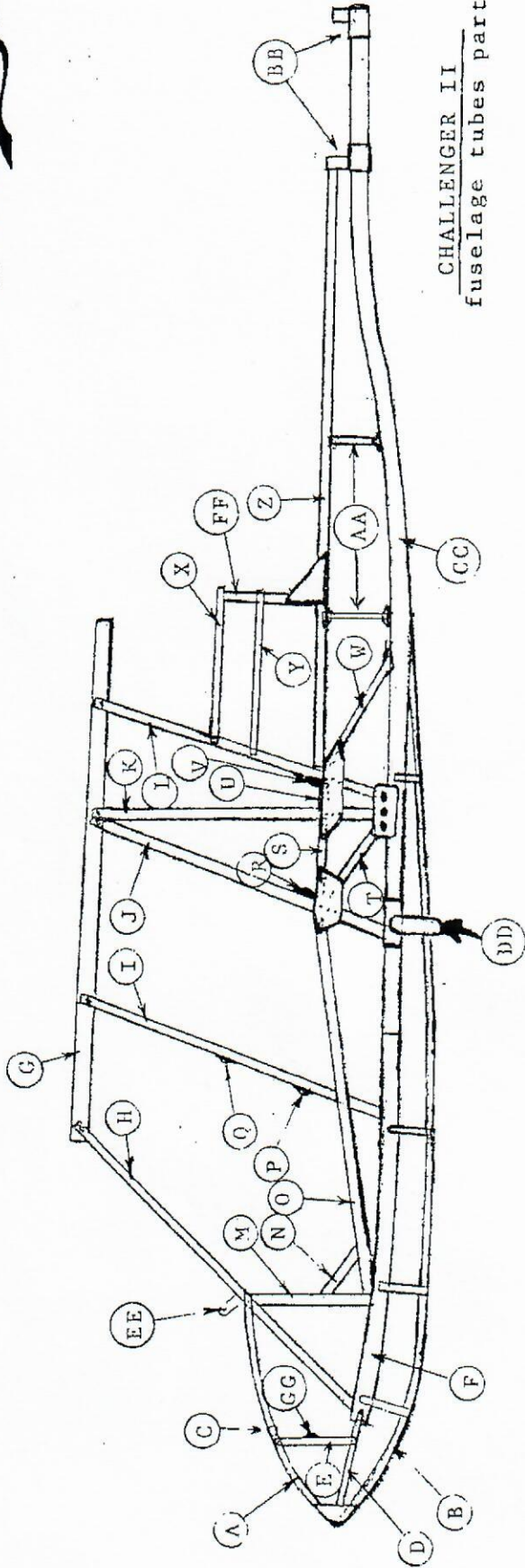

CHALLENGER II  
fuselage tubes part #s

Part # & description

A=	Top stringer
B=	Bottom stringer
C=	Nose spreader(not shown)
D=	Stringer brace
E=	Stringer upright
F=	Front longeron assy.
G=	Root tube
H=	2DT-1 Down tube
I=	2DT-1A " "
J=	2DT-2 " "
K=	2DT-3 " "
L=	2DT-4 " "
M=	2FB-1 Fuselage brace
N=	2FB-3 " "
O=	2FB-2 " "
P=	2FB-15 " "
Q=	2FB-14 " "

Part # & description

R=	2FB-8 Fuselage brace
S=	2FB-4 " "
T=	2FB-5 " "
U=	2FB-6 " "
V=	2FB-9 " "
W=	2FB-7 " "
X=	Rear former top
Y=	Rear former bottom
Z=	2FB-11 Rear boom tube
AA=	2FB-12 Fuselage brace
BB=	Tail post weldment
CC=	Rear longeron
DD=	Main gear weldment
EE=	FWF Windshield former
FF=	2FB-10 Rear former upright
GG=	Pedal stop cross tube

NOTE: Single-place part locations and numbers are similar to two-place; use this drawing to determine location and number, then refer to single-place parts listings to find similar number of part wanted.

QUAD CITY  
**ULTRALIGHT**  
Aircraft Corp.



# Challenger II

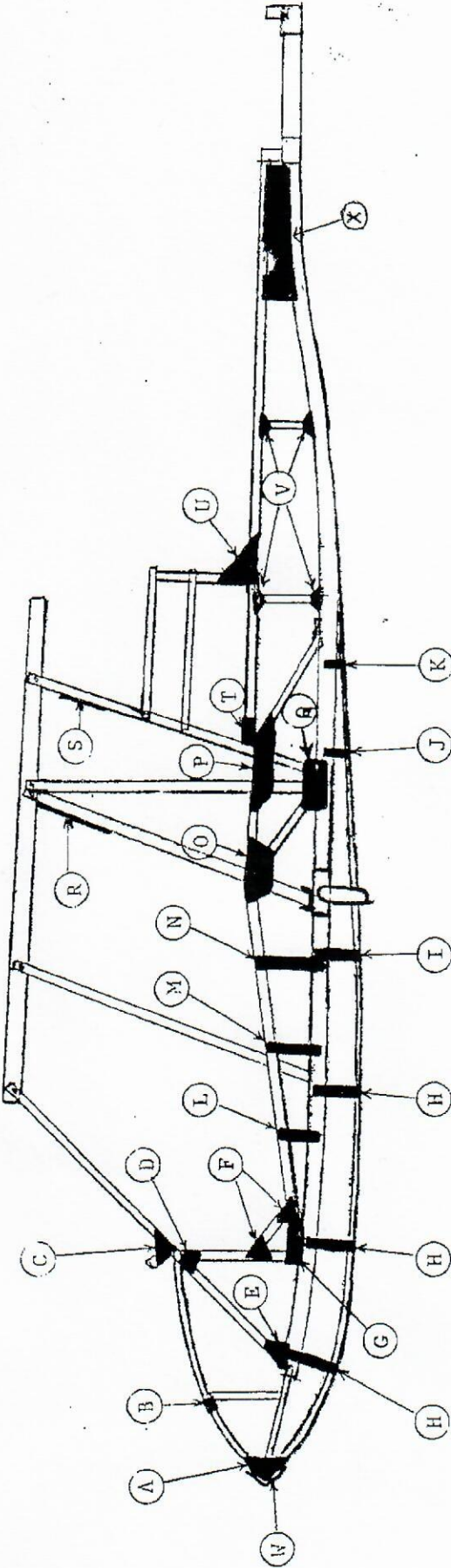

## TWO PLACE GUSSETTS AND RIBS ON FUSELAGE.

PART #	DESCRIPTION	PART #	DESCRIPTION
A= NG-1	Nose gussett	O= 2FG-1	Cluster gussett.
B= FG-10	Spreader gussett	P= 2FG-2	" "
C= FG-6	Windshield gussett	Q= 2FG-3	Downtube gussett
D= FG-7	Triangle gussett	R= 2CP-1	Snap plate
E= FG-4	DT-L Gussett(L or R)	S= 2AM-1	Idler pulley mount
F= EMP-3	Triangle Gussett	T= FG-12	T-Bar gussett(top & bottom)
G= FG-5	Channel Gussett	U= FG-9	fairing
H= 2FSR-6	Stringer rib	V= UB-2	Small U-brkt.
I= 2FSR-5	" "	W= 2FG-11	Nose plate
J= 2FSR-4	" "	X= FG-99	Rear boom brace gussett
K= 2FSR-2	" "		
L= 2FCR-1	Cockpit rib		
M= 2FCR-2	" "		
N= 2FCR-3	" "		

**NOTE:** Single-place part locations and numbers are similar to two-place; use this drawing to determine location and number, then refer to single-place parts listings to find similar number of part wanted.



3610 Coaltown Rd. Moline, IL 61265

